

CAR IDENTIFICATION RECORD

OWNER'S NAME: _____

ADDRESS: _____

SELLING DEALER CODE: _____

DATE OF DELIVERY: _____

DATE OF REGISTRATION: _____

REGISTRATION NO.: _____

CHASSIS NO.: _____

ENGINE NO.: _____

TRANSAXLE NO.: _____

BATTERY MAKE: _____

BATTERY SR. NO.: _____

BATTERY CODE: _____

KEY NO.: _____

**THE WARRANTY ON THIS VEHICLE IS VALID ONLY IF THE DETAILS ARE
FILLED, SIGNED AND STAMPED BY THE SELLING DEALER**

DEALERS SIGNATURE AND STAMP

Following items are provided with your vehicle:

1. Owner's Manual
2. Battery Warranty Card
(if applicable)
3. First Aid Kit
4. Advance Warning Triangle
5. Jack
6. Spare Fuses (Provided in
fuse box)
7. Tool Kit



»XPRES-T

OWNER'S MANUAL



TATA MOTORS

Revision: Rev 00/DEC 2025

Dear Customer,

Welcome to the TATA MOTORS family,
Thank you on the purchase of TATA MOTORS vehicle.

As a global Indian automobile manufacturer, we focus on innovation, technology and build high quality products with exceeding values of “Connecting Aspirations”.

The Owner’s Manual will familiarize you with the operations, equipment description, features that are either as standard or optional on your vehicle. It is requested you read this manual carefully and follow the instructions and recommendations as mentioned.

You are advised to carry out service, maintenance and repairs at TATA MOTORS Dealers and Authorized service centers through out the life of your vehicle. Always use genuine parts for continued performance of your vehicle. Avoid modification, non-genuine accessories fitment on your vehicle. TATA MOTORS does not carry any liability arising due to it. Always keep this manual in the vehicle.

You can contact our dealer or Customer Assistance toll free no.(1800 209 8282) in case of any query or support required.

Information provided in this Owner’s Manual is explicit at the time of publication. However, as TATA MOTORS continues to make changes and improve products, it reserves the right to make changes in this manual or any product at any time, without notice and without any obligations.

We look forward for your continued association with us for many years to come.

Wishing you a Safe and pleasant driving experience.

TATA MOTORS PASSENGER VEHICLES LTD.

Bombay House, 24, Homi Mody Street,
Mumbai, (MH) - 400 001, Maharashtra, India

01. SAFETY

Important Information	1
Seats	4
Seat Belts	5
Supplementary Restraint System (SRS) (airbags) (if equipped)	9
Children On Board	14
Anti-lock Braking System (ABS)	21
Additional Safety Features (if equipped)	22
Anti-theft Device-immobilizer	24

02. OPENING AND CLOSING

Keys	25
Flip Key	27
Flip Key Features	28
Doors	29
Windows	30
Opening The Bonnet	32
Tail Gate Opening	33
Fuel Lid	33

03. DASHBOARD AND FEATURES

Cockpit (MT)	35
Digital Display (4" Inch) (if equipped)	36
Tell Tales	58
Audio Reminders (if equipped)	63
Combi-switch (RH Stalk) (if equipped)	64
Combi-switch (LH Stalk) (if equipped)	66
Dashboard Controls	67
Steering Mounted Controls (LHS) (if equipped)	67
MIC (if equipped)	68
Infotainment System Display (if equipped)	68
USB Port (if Equipped)	69
Power Socket	70
Antenna	70
Roof Grab Handle	71
Tag Holder	71
Roof Lamp	71
Front Lamp	72
Tail Lamp	72
Side Indicator Lamp	73

CONTENTS

04. STOWAGE AREAS

Storage Compartment	75
Hooks (If equipped)	78

05. CLIMATE CONTROL

Air Distribution	79
Air Vents	80

06. STARTING AND DRIVING

Pre Driving Checks	81
Driving Tips	82
Seat Adjustments	86
Rear View Mirrors	88
Sun Visors (if equipped)	90
Electric Power Assisted Steering (EPAS)	90
Steering Wheel Adjustment	91
Steering Lock And Ignition Switch (If equipped)	92
Starting And Stopping (without PEPS)	93
Engine Passive Start - Conditions	94
Engine Passive Stop - Conditions	95

Gear Shifting	95
Reverse Gear	96
Driving	97
Starting The Engine	97
Braking	98
Creeping Feature	99
Parking Brake	100
Vehicle Parking	100

07. EMERGENCY AND BREAKDOWN ASSISTANCE

Emergency Equipment	103
Spare Wheel Removal Process	105
In Case Of Flat Tyre	106
Jump Starting Your Car	109
Towing	111
Fuses	113
Bulb Specification	121
24 X 7 Roadside Assistance	122

08. MAINTENANCE

Maintenance And Service	125
Engine Compartment – Petrol (MT)	126
Engine Oil Level	127
Brake Fluid Level	128
Engine Coolant Level	128
Windshield Washer Fluid Level	129
Battery	130
Spark Plug (petrol)	132
Tyres	132
Remote Key Battery Replacement	135
On Board Diagnostic (OBD II) System	136
Service Instructions	137
Service Schedule	138
Vehicle Parking For Long Duration (non - Use Maintenance)	143

09. TECHNICAL INFORMATION

Fuel Specification	145
Lubricant Specification	146

Technical Specifications	147
Vehicle Dimensions	150
Aggregate Identification Numbers	151

10. CAR CARE AND VALUE ADDED SERVICES

Car Care	153
Value Care - AMC	156
Value Added Services	159
Vehicle Exterior Enrichment	161
Vehicle Interior Enrichment	162

11. WARRANTY - TERMS AND CONDITIONS

Warranty - Terms And Conditions	163
Extended Warranty - Terms And Conditions	165

12. ENVIRONMENT SAFETY

Environment Safety	167
--------------------	-----

IMPORTANT INFORMATION

In this Owner's Manual, you will find the text under the heading "WARNING" and "NOTE" which highlights important information. Pay particular attention to these highlighted messages. The Images / Illustrations in this owner's manual are only for reference. It may defer with actual vehicle.

NOTE

Indicates additional information that will assist you in gaining the optimum benefit and care for your vehicle.

WARNING

Indicates procedures or information that must be followed precisely in order to avoid the possibility of severe personal injury and serious damage to the vehicle.

CAUTION

It indicates to be careful. You are capable of doing something that might result

in damage to equipment.

Vehicle Scrapping

Your vehicle is equipped with SRS Air Bags and Seat Belt Pretensioner, ensure to remove and dispose it by qualified service center or by Tata Motors Authorised Service Centre before scrapping your vehicle.

Important Information

Vehicle In Water Logged Condition



- Before driving through water logged areas ensure that water is below tailpipe level
- Unseen pot holes could damage under surface of the vehicle
- Drive slowly and maintain constant acceleration
- After passing the water logged area ensure to press brakes intermittently to dry the brake disc

WARNING

- Do not drive through heavy water logged area
- Water may enter into vehicle interior and engine compartment which may damage electrical, electronic circuits

SAFETY

and cause hydrostatic lock of engine.

- Battery may get damaged or short circuited

Vehicle In Flood

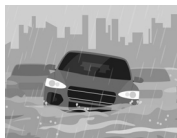

WARNING

- If your vehicle gets flooded wait for water level to recede
- Once the water is receded, approach the vehicle, open all doors and let the water inside the vehicle get drained completely
- Remove floor carpet and open the rubber/plastic grommet provided on floor board, stepney space for water to recede from interior flooring of the vehicle completely.

- Push your vehicle to safe place do not try to start the vehicle

NOTE

If the vehicle is submerged in water, we recommend to kindly contact TATA MOTORS Authorised Service Center.

Vehicle In Fire



In case of vehicle fire, immediately evacuate vehicle and contact local fire tender responder. They possess proper training and equipment to safely extinguish vehicle fire.

Contact nearest TATA MOTORS Authorised Service Center for further assistance.

WARNING

- Do not modify your vehicle.
- Do not install high-wattage bulbs, non-genuine lamps, horns
- Do not modify suspension, wheels, tyres
- Stick to manufacturer recommended parts. Safety matters
- Avoid tampering with the wiring harness, it can lead to short circuits.
- Be cautious with retrofitted CNG kits. Improper installation can cause leaks or fire hazards.

CAUTION

Do not store or carry inflammable materials in the vehicle

General Safety Tips

- Safety consciousness not only ensures your safety and the safety of other road users, but it also helps to reduce the wear and tear on your vehicle.
- How quickly you make decisions to avoid an accident.
- Your ability to concentrate.
- How well you can see and judge objects.
- How well familiar you are with your vehicle controls and its capabilities.
- Turn 'ON' the side indicators at least 30 meters before taking a turn or changing the lane.
- Decelerate to a safe speed before taking turn. Do not apply brakes during cornering.
- When overtaking other vehicles, watch out for the oncoming vehicle.
- Never drive under the influence of alcohol or drugs.
- If your vehicle is equipped with info-

tainment/ navigation system, set and make changes to your travel route only when the vehicle is parked.

- Program radio presets with the vehicle parked, and use your programmed presets to make radio use quicker and simpler.
- If your car gets flooded and has soaked carpeting or water on the flooring, you should not try to start the engine, we recommend to kindly contact TATA MOTORS Authorised Service Center.
- While re-fueling switch OFF the engine and avoid the usage of mobile phone

While Handling Hot Parts

- Never remove the coolant cap when the engine is hot. The engine coolant is under high pressure and could splash on to skin/eyes causing severe burns.
- Stay rod becomes hot enough after vehicle running, be careful while using it. Touch only rubber part available on stay rod.
- Never touch engine exhaust after vehicle running as it will cause severe injury.
- Do not touch tyre and wheel rim when it is hot after a long journey it may cause burn injury.

SAFETY

SEATS

Your vehicle is provided with good seating comfort. To make your journey more safe and enjoyable we recommend you to follow below warnings and cautions.

Driver's seat

WARNING

- Do not adjust seat while driving / vehicle is moving. Doing so could result in loss of control, and an accident causing death, serious injury, or property damage.
- Always sit as far back as possible from the steering wheel while maintaining comfortable control of the vehicle. Fitment of seat covers on driver seat with airbags is strictly prohibited.
- Do not keep any sitting cushion on seats. This may result in serious or fatal injury in the event of accident.
- After adjusting the seat make sure it is securely locked by pushing it forward and backwards without using

lock release lever. Sudden or unexpected movement of the driver's seat could cause to lose control of the vehicle resulting in an accident.

- All passengers must be seated in seats and restrained with seat belt properly while riding in vehicle
- If there are occupants in the rear seats, be careful while adjusting the front seat position.

Front Passenger Seat

WARNING

Never ride in a vehicle with a front seat-back fully reclined. This may lead to serious injuries. Fitment of seat covers on front passenger seat with airbags is strictly prohibited.

Rear Seat Back

WARNING

The rear seatback must be securely latched. If not, passengers and objects

could be thrown forward resulting in serious injury in the event of a sudden stop or collision. Luggage and other objects in boot should be kept flat. If large, heavy, or piled they must be secured properly. No passenger should ride in the boot area or sit or lie on folded seat-backs while the vehicle is in motion.

Applicable for Hatchback/SUV

WARNING

- Under no circumstances should objects be piled higher than the seat-backs. Failure to follow these warnings could result in serious injury in the event of a sudden stop or collision. Ensure that objects are securely fastened.
- Storing items against seatback or in any other way interfering with proper locking of a seatback could result in serious or fatal injury in a sudden stop or collision. After resetting the seatback to its seating position make sure it is securely latched

by pushing it forward and backwards.

⚠ CAUTION

Your hands might cut or injured by the sharp edges of the seats mechanism during looking for small objects trapped under the seats or between the seat and the center console.

Head Restraint (If equipped)

Front Seat

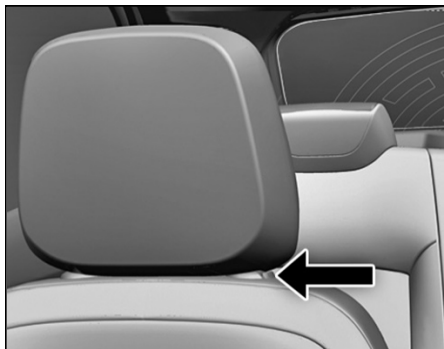

Adjust the head restraint so that it is as close to the head as possible and the center of the head at eye level. This will reduce the risk of injury to the head and neck in the event of an accident or similar situation.

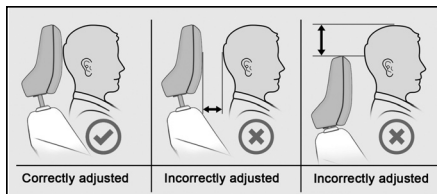

⚠ WARNING

Do not drive the vehicle without the seat head restraints. Head restraints are intended to help reduce injuries during an accident.

SEAT BELTS

This section describes your Vehicle's Seat belts, Airbags and Child restraints system. Please read and follow all these instructions carefully to minimize risk of severe injury or death.

- Seat belts are the primary restraints system in the vehicle. All occupants, including the driver, should always wear their seat belts. Your vehicle is equipped with three point seat belts for all occupants.
- Sit back and adjust the driver seat. Make sure that your seat is adjusted to a good driving position and the back of the seat is upright.

SAFETY

Buckling of Seat Belt

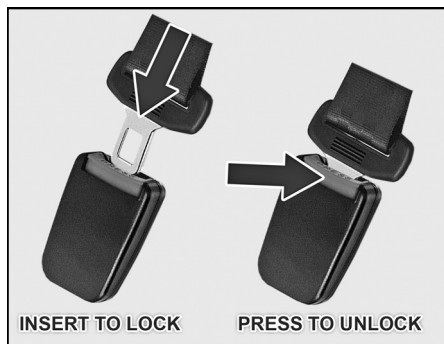

- Grasp the tongue then slowly pull out the seat belt over the shoulder and across the chest. When the seat belt is long enough to fit, insert the tongue into the lock buckle until you hear a “CLICK” which indicates that the seat-belt is securely locked. (Refer “INSERT TO LOCK” image)
- Position the lap portion of seat belt across your pelvic bone, below your abdomen. To remove slack, pull up a bit on the shoulder seat belt. To loosen the lap portion seat belt if it is too tight,

tilt the tongue and pull on the lap seat belt. A snug seat belt reduces the risk of sliding under the seat belt in a collision. Ensure that the seat belt running over the body (shoulder segment and lap segment) does not have any twist. Twisted seat belt may not offer effective protection when required.

- Ensure that the seat belt webbing is straight and not twisted. Twisted seat belts may not work properly in case of collision.

Releasing the Seat Belt

To release the seat belt, push the red button on the lock buckle (refer “PRESS TO UNLOCK” image). Ensure to hold seat belt during unlocking and release it slowly towards the seat belt mounting. The seat belt will automatically retract to its stowed position. If necessary, slide the tongue down the webbing to allow the seat belt to retract fully.

WARNING

Due to retractor reversal action if you leave the seat belt from the unlock position it may hit you or parts like glass in the way which may cause injury to you or damage to the vehicle.

WARNING

- Each seating position and seat belt assembly must be used by one occupant.
- Be careful not to damage or tamper the seat belt webbing or hardware. Inspect the seat belt system period

ically, checking for cuts, frays, or loose parts. A frayed or torn seatbelt could rip apart in a collision and leave you with no protection.

- If the seat belt webbing or hardware is damaged, get it replaced immediately at TATA Motors Authorized service centre.
- Do not insert any items such as coins, clips, etc. into the seat belt buckles, and be careful not to spill liquids into these parts. If foreign materials get into a seat belt buckle, the seat belt will not work properly.
- Do not wear seat belts over hard, sharp or fragile items in clothing, such as pens, keys, spectacles etc.
- Do not use any accessories on seat belts or modify in any way the seat-belt system. Devices claiming to improve occupant comfort or repositioning the seat belt, can reduce the protection provided by the seat belt and increase the chance of serious injury in a collision.



Use of Seat Belts for Pregnant Woman

WARNING

- Pregnant woman must wear a correctly positioned seat belt. It is safer for mother as well as unborn child.
- Pregnant woman should wear the lap part of the seat belt across the thighs and as snug across the hips as possible. Keep the seat belt low so that it does not come across the abdomen. That way the strong bones of the hips will take the force if there is a collision.



Seat Belt Warning Lamp

Seat	Lamp
Driver	
Front Passenger	
Rear Passenger	

Your vehicle is equipped with Seat Belt Reminder (SBR) for all occupants.

NOTE

*For Driver and Co-Driver Seat
Whenever an occupant is not sitting in any seating position then seat belt reminder beeping sound will not be played in instrument cluster.
If any material is kept on any seat then SBR beeping sound may be played in instrument cluster. Please do not keep*

SAFETY

any material on seat.

- If the driver or any passenger do not fasten the seat belt, seat belt reminder lamp will blink and a buzzer will sound for pre-defined duration until the seat belt is buckled.
- If passenger seat is occupied by child (without child seat), system may detect occupancy and warn with seat belt warning. It is not taken to mean child can occupy passenger seat and use seat belt. Please refer CRS section for recommended seating position if child is sitting with child seat.

***i* NOTE**

Fitment of seat covers on any seating position is strictly prohibited. It may affect the function of occupant sensor.

Seat Belts With Pre – Tensioner (If equipped)

You can use the pre-tensioner seat belts in the same manner as ordinary seat belts. The seat belt pre-tensioner system works in conjunction with the Supplementary Restraints System (SRS-Airbags). In the event of a collision, as may be necessary, pre-tensioner tightens the seat belt so that it fits the occupant's body more snugly. When pre-tensioner activates, there could be some noise and release of smoke. This is normal and there are no health hazards or fire risk.

Seat Belt With Load Limiter (If equipped)

You can use the load limiter in the same manner as ordinary seat belts. The seat belt load limiter system works in conjunction with the Supplementary Restraints System (SRS-Airbags). In the event of a collision, as may be necessary, load limiter reduces the load on the rib cage region of the occupant.

If the vehicle has been involved in a collision, get it inspected immediately at TATA MOTORS Authorized Service Centre.

SUPPLEMENTARY RESTRAINT SYSTEM (SRS) (AIRBAGS) (if equipped)

The SRS [Supplementary Restraint system] is designed to provide protection to occupants in case of collision or sudden impact, when crash is detected, the SRS airbag system deploys airbags to help reduce the risk of injury to the occupant. It works in conjunction with seat belts.

There are 2 airbags provided in your car:

- 1.Driver Airbag
- 2.Front Passenger Airbag

The driver airbag is mounted in the centre of the steering wheel. The front passenger airbag is located inside the dashboard in front of the passenger seat. The airbags have suitable indications on steering wheel and on dashboard. The word 'AIRBAG' is marked at adjacent locations of respective airbags

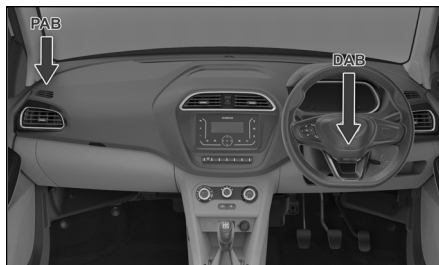

i NOTE

The above image is for reference purpose only.

The airbag 'SRS' system comprises of the following components depending upon the provided safety features in your vehicle.

- Seat belt Pre-tensioners
- Seat belt with load limiters
- Airbag 'SRS' ECU (Electronic Control Unit)
- Collision Sensors
- SRS wiring harness
- SRS Warning lamp

The System is active when ignition switch

is in the "ON" position or the ignition mode is "ON". Airbags are designed to inflate in severe collisions. In the event of a collision, the collision sensors will detect signals, and if the Airbag ECU judges that the signals represent a severe collision, will trigger the airbags. The inflated Airbags provide a cushion to the occupants. The Airbag inflates and deflates quickly that you may not even realize that it has activated. The Airbag will neither hinder your view nor make it harder to exit the vehicle.

Airbag inflation is virtually instantaneous and occurs with considerable force, accompanied by loud noise and smoke, which is normal. The inflated airbag, together with seat belts, limit the movement of an occupant, thereby reducing the risk of injury.

When an airbag inflates, you may see some smoke-like particles. The particles are a normal by-product of the process that generates the non-toxic gas used for airbag inflation. These airborne particles may irritate the skin, eyes, nose, or throat. If you have skin or eye irritation, rinse the area with water. For nose or throat irrita-

SAFETY

tion, move to fresh air. Also sometimes the smoke can cause breathing problems, in such cases, it is recommended to get fresh air promptly.

It is not advisable to drive your vehicle after the airbags have been deployed. If you are involved in another collision, the airbags will not be in place to protect you.

NOTE

- *Open your windows and doors as soon as possible after collision to reduce prolonged exposure to the smoke and powder released by the inflating Airbag.*
- *Do not touch the Airbag container's internal components immediately after an Airbag has inflated. The parts that come into contact with an inflating Airbag may be very hot.*
- *Always wash exposed skin areas thoroughly with lukewarm water and mild soap.*

WARNING

- Even in vehicles with Airbags, you and your passengers must always wear the seat belts provided. In order to minimize the risk and severity of injury in the event of a collision.
- ALWAYS use seat belts and CRS – during every trip and at all times. Even with airbags, you can be seriously injured or killed in a collision if you are not wearing seat belt properly or not wearing seat belt when airbag inflates.
- Occupants should never sit or lean unnecessarily close to the Airbags.
- Move your seat as far back as possible from front Airbags, while still maintaining control of the vehicle.
- All occupants should sit upright with the seatback in an upright position, centred on the seat cushion with their seat belt on, legs comfortably extended and their feet on the floor until the vehicle is parked and the engine is turned off.

- If an occupant is out of position during collision, the rapidly deploying Airbag may forcefully contact the occupant causing serious or fatal injuries.
- Do not allow the front passenger to place their feet or legs on the dashboard.
- Do not allow the passenger to ride in the front seat when the front passenger Airbag OFF indicator is illuminated.

Wrong Seating Position



SAFETY



WARNING

- Never place your arm over the airbag as a deploying airbag can result in serious arm fractures or other injuries.
- Do not allow the passengers to lean their heads or bodies onto doors or place objects between the doors and passengers when they are seated on seats equipped with side and/or curtain Airbags (if equipped).
- Do not place or stick any item/s in the vehicle, except at designated lo-

cations (such as utility bins, cup/bottle holders, boot space etc). Loose items may act as a projectile during a collision and cause severe to fatal injuries.

- Please be aware that any unsecured item in your vehicle, such as your pet, unsecured CRS or a laptop, can become a potential hazard in the event of a collision or sudden stop, causing injuries to occupants in the vehicle.
- Coat hooks (if provided), must be used only for that purpose. Never hang other items on to those hooks. This could affect deployment of the Airbags, and may lead to severe to fatal injuries.
- ALWAYS contact your TATA MOTORS authorised service centre if the vehicle is damaged, even if airbag has not inflated or any part of an airbag module cover shows sign of cracking or damage.

WARNING

If your SRS malfunctions, the Airbag may not inflate properly during a collision thereby increasing risk of serious injury or death. If any of the following conditions occur, your SRS is malfunctioning:

- The SRS warning lamp does not turn 'ON' when the ignition switch is placed in the 'ON' position for few seconds.
- The SRS warning lamp stays 'ON' after illuminating
- The SRS warning lamp comes 'ON'/stays 'ON' while the vehicle is in motion.
- The SRS warning lamp blinks when the engine is running.

We recommend the customer to immediately visit TATA MOTORS authorised service centre and get the SRS system inspected if any of the above conditions occur.

⚠ WARNING

- Never make any modifications to your vehicle. The modifications carried out, but not limited to the vehicle frame, bumpers, front fenders, ride height, suspension, seat belts, interior trims, steering wheel (especially holders), are not acceptable. This will affect the intended performance of SRS.
- Fitment of bull bars, seat covers on seats with airbags etc, is strictly prohibited, unless authorised by TATA MOTORS. This will affect the intended performance of SRS.
- If you need to make any modifications to accommodate any disability you may have, please contact your Authorized TATA MOTORS Dealer for necessary guidance.
- Do not tamper with SRS in any way. This will lead to unexpected performance of system and may cause serious injury or death.

Airbag Warning Sticker On Front Passenger Sun Visor

The Airbag Warning Symbol on sun visor reminds of the extreme hazards associated with the use of a rearward-facing child restraint on front passenger seat during airbag deployment. It does not mean that a child cannot occupy front passenger seat and use seat belt. Please refer CRS section for recommended seating position for children.

⚠ WARNING

Never use a rearward facing child restraint on a seat protected by an active Airbag in front of it, Death or serious injury to the child can occur.

Airbag Deployment Conditions**When front airbags should not deploy?**

Minor frontal collision: Seat belt (if worn), offers adequate occupant protection in low severity collisions. The airbags are triggered only when there is a collision severe enough to trigger the airbags. Deployment of frontal airbags is not beneficial in low severity collisions.

Side collision: During a side collision, occupants tend to move sideways. Therefore, deploying frontal air-bags in such situations will not benefit the occupants.

Rear collision: During a rear collision, occupants tend to move (rearwards) away from frontal airbags. Therefore, deploying frontal airbags in such situations will not protect the occupants. Head restraints and seat belts provide occupant protection dur-

SAFETY

ing a rear collision.

Rollovers collision: During a rollover collision, unbelted occupants may float inside the passenger compartment. This will increase the risk of injuries and may prove to be fatal. Wearing seat belts provide highly effective occupant protection during rollover collision. Front airbags, are not designed to deploy in a rollover as frontal airbags cannot offer any protection in rollover collision.

When front airbags deploy with minor or no visible vehicle damage?

The airbags are triggered only when there is a collision severe enough to trigger the airbags. The extent of vehicle damage is not always the correct indicator for airbag deployment. In some extreme/rare conditions; of rough road driving, running into a curb or hitting other fixed objects; the airbags may deploy depending upon the severity of collision. In some of these conditions, damage to the vehicle may be minor or not be readily visible.

When front airbags not deploy, even with exterior visible vehicle damage?

The airbags are triggered only when there is a collision severe enough to trigger the airbags. The amount of visible vehicle damage is not always the correct indicator for airbag deployment. Some collisions can result in visible damage but with no airbag deployment, because the airbags would not have been needed or would not have provided protection even if they had deployed. Seat belts, if worn, offer adequate occupant protection in such cases.

CHILDREN ON BOARD

WARNING

- Do not leave unattended children in your vehicle.
- During reversing and parking, ensure that children are far away from the vehicle.

WARNING

- Do not put the safety seat belt under your child's arm or behind its back.
- Do not use pillows, books or towels to boost your child's height.
- Do not allow children to stand up or kneel on either the rear or the front seats. An unrestrained child could suffer serious or fatal injuries during a collision.
- Do not install a booster seat or a booster cushion with a seat belt that is slack or twisted.

Child Restraint System (CRS)

TATA MOTORS strongly recommends the use of Child Restraint Systems (CRS) for all children up to 36 Kg and to be placed at recommended positions only (Refer CRS Position table in this section).

ISOFIX

CRS can be installed in the vehicle using seat belts and/or ISOFIX with support leg (if equipped) or ISOFIX with Top Tether (if equipped). These ISOFIX attachment points are located on rear outboard seating locations which enables quick and safe child seat engagement.



ISOFIX



Top Tether

Top Tether mounting anchorages are located at backside of rear outboard seats.

The harness system of CRS holds the child in place, and in a collision, acts to keep the child positioned in the seat and reduce the risk of injuries.



Keep children in a forward-facing or rearward facing CRS with a harness until they reach the size or age or weight limit recommended by your CRS manufacturer.

Selection And Installation Of Crs

Always select the CRS that complies with latest safety standards (AIS 072 / ECE

SAFETY

R44 / ECE R129). The CRS are classified according to the child's size, height and weight. Select the appropriate CRS for your child. Ensure that the child fits properly in the CRS and it is securely installed in the vehicle.

While installing the child seats always adhere to the directions in this Owner's Manual as well as those provided by the child seat's manufacturer.

Tata Motors recommends Joie i-Spin Safe or Joie i-Spin 360 R i-Size seats for up to 18 Kg children. These seats are available at TML dealerships.



i NOTE

Tata Motors recommends to keep the highlighted device in close condition while using Joie i-Spin Safe or Joie i-Spin 360 R seat in car.

Installing The Child Seat On Front Passenger Seats

- Adjust the front passenger seat back up to its vertical position as per requirement, so that it can create adequate contact between passenger seat backrest & child seat.
- Adjust the front passenger seat forward or backward as per requirement, so that there could not be any contact between front passenger seat & child seat or child present behind it.
- If required, adjust the front passenger seat height to its suitable position.
- While installing child seat on front passenger seating position, adjust the buckle to its suitable position of rotation.
- While installing forward facing child seat for 15 to 18kg children on front passenger seating position, adjust the front passenger seat to its rearmost position.

Installing The Child Seat On Rear Passenger Seats

- If required, adjust the front seat so that there could not be any contact between front seat & child seat or child present behind front seat.
- While installing forward facing child seats adjust the rear seat head restraints to its lowermost position or remove it if required & keep it at safe location to reinstall it whenever adult passenger is sitting at that position.
- While installing child seats on rear out-board seating position, adjust their respective buckles to its required position of rotation.

Correct CRS Position



Incorrect CRS Position



SAFETY

Recommended CRS Position as per the Vehicle Matrix

The suitability of seat position for carriage of children and recommended category of CRS is shown in the table as per the child group.

NOTE

The child's life is at risk in a collision if the CRS is not properly secured in the vehicle. Be sure to secure the child in the restraint system according to the manufacturer's instructions

WARNING

Do not use an infant carrier or a child safety seat that “hooks” over a seat-back, it will not provide adequate protection in a collision.

Recommended CRS Positions (CRS Fastened With A Safety Belt)					
Group	Mass Group	Front Passenger	Rear Out-board LH	Rear Out-board RH	Rear Centre
0	Up to 10 kg	X	U	U	X
0+	Up to 13 kg	X	U	U	X
I	9 to 18 kg	UF	U	U	X
II	15 to 25 kg	UF	U	U	X
III	22 to 36 kg	UF	U	U	X

X: Seat Position not suitable for children in this mass group.

U: Suitable for “universal” category restraints approved for use in this mass group.

UF: Suitable for forward facing “universal” category restraints approved for use in this mass group.

⚠ CAUTION

A CRS in a closed vehicle can become very hot. To prevent burns, check the seating surface and buckles before placing your child in CRS.

⚠ WARNING

- Do not modify CRS in any way.

⚠ CAUTION

- Do not install a booster seat or a booster cushion with only the lap strap of the seat belt or a seat belt that is slack or twisted.
- Do not leave any toys or other objects loose in the CRS or on the seat while the vehicle is in motion.

Recommended CRS Positions (CRS That Can Be Used With ISOFIX System)

Group	Mass Group	Category Of Child Seat	Front Passenger	Rear Outboard LH*	Rear Outboard RH*	Rear Centre
0	Up to 10 kg	E	X	IL	IL	X
0+	Up to 13 kg	C, D, E	X	IL	IL	X
I	9 to 18 kg	D, C, B, B1, A	X	IL IUF	IL IUF	X
II	15 to 25 kg		X	IL	IL	X
III	22 to 36 kg		X	IL	IL	X

IL: The seat is suitable for the ISOFIX child seats with “Semi-Universal” approval.

IUF: The seat is suitable for forward facing child seats and is permitted for use in this weight category.

X: The seat is not equipped for the ISOFIX system.

*Rear outboard seating positions are suitable for ISO/R3, Class C CRS.

SAFETY

After a collision, we recommend to get seat belts, seats, ISOFIX and top-tether anchorages (as may be applicable) investigated at TATA MOTORS Authorized Service Centre.

Each CRS should be used for one child only.

WARNING

If the airbag SRS warning indicator in the instrument cluster illuminates continuously, it means that there is malfunction in the system. Remove the CRS from front passenger seat and contact your TATA MOTORS Authorized Service Centre.

Child Lock



Child lock are provided on both rear doors. It is used for safety of a child.

Child safety lever to be used for safety of child for preventing them to open rear door while seating in passenger seat to avoid accident while vehicle is moving.

Both the rear doors of the vehicle are provided with a child proof lock. Push the lock lever (located on vertical face of the door) downward before closing the door. The door which has been locked by activating the child lock cannot be opened from in-

side. It can be opened only from the outside.

NOTE

- *Lift the lock lever upward to deactivate the childproof lock when not required.*

ANTI-LOCK BRAKING SYSTEM (ABS)

ABS regulates brake pressure in such a way that the wheels do not lock when you brake. This allows you to continue steering the vehicle when braking.



The ABS warning lamp in the instrument cluster lights up when the ignition is switched on. It goes out when the engine is running.

WARNING

- If ABS is faulty, the wheels could lock when braking. The steer ability and braking characteristics may be severely impaired. There is an increased danger of skidding and accidents.
- Drive on carefully. Have ABS checked immediately at a TATA MOTORS Authorized Service Centre as soon as possible.

While Braking

- In case of emergency braking, press the brake pedal fully. This allows the ABS to regulate braking force and maintain directional control of vehicle.
- When ABS is active driver may feel brake pedal pulsating and very low (ABS) motor activation noise from engine compartment which is normal during braking.

WARNING

- ABS may not shorten the distance in all situations
- ABS system will have the effect of increased stopping distance due to conditions such as gravel, pot holes, slippery surfaces, wet road, ground covered with snow etc.
- Travelling on bad road, panic braking brake pedal may become hard this is due to ABS system taking control. ABS will not compensate for bad road, weather conditions and poor driving judgment. Always drive carefully in adverse weather and traffic condition.
- Always keep safe distance and adhere to speed limits

SAFETY

ADDITIONAL SAFETY FEATURES (if equipped)

Electronic Brake Force Distribution (EBD)

EBD monitors and controls the brake pressure on the rear wheels to improve driving stability while braking. 

EBD provides optimal braking pressure distribution between front and rear wheels to optimize braking distance and to ensure vehicle stability by means of lowering braking pressure at rear wheels.

WARNING

- If EBD  is malfunctioning, the rear wheels can lock, e.g. under full braking. This increases the risk of skidding and an accident.
- You should therefore adapt your driving style to the different handling characteristics. Have the brake system checked immediately at a TATA MOTORS Authorized Service Cen

tre as soon as possible.

Electronic Stability Program (ESP)

ESP monitors driving stability and traction.



If ESP detects that the vehicle is deviating from the direction desired by the driver, one or more wheels are braked to stabilize the vehicle. The engine output is also modified to keep the vehicle on the desired course within physical limits. ESP assists the driver when pulling away on wet or slippery roads. ESP can also stabilize the vehicle during braking and acceleration.

Cornering Stability Control (CSC)

Corner stability Control supports / stabilizes vehicle during partial braking on curves by reducing pressure at required inner wheel of the vehicle.

This helps to reduce probability of vehicle over steering during cornering.

Engine Drag Torque Control (EDTC)

On slippery road conditions during in gear

braking or shift down of gear or sudden throttle release on a curve road.

This causes high Engine drag on the driven wheel resulting into brake slip situations without any brake application.

This makes vehicle highly under steerable.

EDTC controls such brake slip on the driven wheels by increasing the engine torque to makes the vehicle stable and steerable.

Traction Control System (TCS)

The Traction Control system continuously monitors the front and rear wheel speeds. In event of traction loss, the system reduces wheel spin by reducing the engine torque output and by varying the brake pressure on individual wheels.

WARNING

For optimal performance of the TCS feature, the tyres must be in good condition and must be inflated as per recommended pressures.

Hill Hold Control (HHC)

Hill Hold Control is a comfort function. The main intend is to prevent the vehicle from rolling backwards while driving on an inclined surface. HHC holds the brakes for a predefined time while you switch your foot from brake pedal to accelerator pedal thus preventing vehicle roll back due to the incline.

The HHC will function on both vehicle facing uphill and downhill if the following conditions are met.

Vehicle must be equipped with HHC

Vehicle must be on sufficient gradient

Parking brake must not be engaged

Correct gear is engaged: Vehicle facing downhill – Reverse gear and Vehicle facing uphill - Forward gear

After Impact Braking (AIB)

- After impact braking system is activated automatically and brakes the car in a safe manner to mitigate secondary collision.
- Hazard & brake lights are triggered to intimate surrounding users of an emer-

gency situation. Warning lights will continue flashing after vehicle comes to a standstill.

- The driver can override the system by depressing the brake/acc pedal if there is a risk of being hit by following traffic.
- The basic assumption is that the brake system is intact after the primary impact.
- Mitigate impact/severity of subsequent collisions.

Panic Brake Alert (PBA)

Panic brake alert warns vehicles approaching from behind when emergency or heavy braking takes place. The PBA is designed to trigger Hazard lamps automatically, which will act as an immediate warning to vehicles directly behind and nearby. PBA is an immediate and urgent warning to all vehicles around thus improving their response time to unforeseen braking situations.

The PBA feature gets activated if the vehicle speed is greater than 50 kmph and if the system detects a panic braking scenario.

SAFETY

ANTI-THEFT DEVICE-IMMOBILIZER

Immobilizer system is designed to prevent vehicle theft by electronically disabling the engine ignition system. The engine can be started only with vehicle's original Immobilizer ignition key which has an electronic identification programmed code.

i NOTE

Use only one key, the other should be kept in a safe location. Note down "key Tag no." information (and keep it safe) which is required while getting new/spare keys. Remember that it is not possible to prepare new/spare keys without the "key Tag number." Take precaution about key, as without key vehicle cannot be started.

Vehicle Condition	Immobilizer Lamp Status	Vehicle State	Meaning / Function Of The State
Ignition OFF	Blinking	Locked	Vehicle Immobilized and awaiting electronic key
Ignition ON	OFF	Unlocked	Normal condition and ready to start the vehicle
Ignition ON	ON	Locked	- Problem with key (Wrong key used to start vehicle) - Problem with Immobilizer system. Contact a TATA MOTORS Authorized Service Centre
Ignition ON	Blinking	Unlocked	- Contact a TATA MOTORS Authorized Service Centre immediately.

KEYS

Unlocking Principle

The transponder in the ignition key carries a Unique Identification Code (UID). The vehicle unlocks when the code on the key matches with the code on the Engine Management System (EMS). In case of PEPS variant, Immobilizer function is provided by PEPS ECU.

Engine Starting

When the key is inserted / kept in vehicle and the ignition is switched to 'ON', all codes are communicated within key, Immobilizer and EMS. The engine will start only if all the codes match.

Loss Of Keys

If one of the keys is lost, Contact the TATA MOTORS Authorized Dealer/Service Center immediately.

WARNING

- Do not turn 'ON' ignition switch by using key with any type of metal wound around its grip or in contact

- with it. This may be detected as abnormal condition by immobilizer and prevent engine from starting.
- Do not leave the key in high temperature areas. The transponder in it will behave abnormally when reused.
 - Do not try to start the vehicle when the Immobilizer indicator lamp on the instrument cluster is glowing. In this condition the vehicle will not start and the vehicle's battery will also be drained due to frequent cranking.

OPENING AND CLOSING

Types Of Key (as applicable)

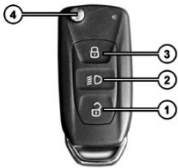
Sn	Name	Remote Key	Description
1	Mechanical key		<ol style="list-style-type: none">1. Locking all doors2. Unlocking all doors
2	Flip Key		<ol style="list-style-type: none">1. Unlocking all doors2. Approach Light /follow me3. Lockng all doors4. Key blade in / out button

FLIP KEY

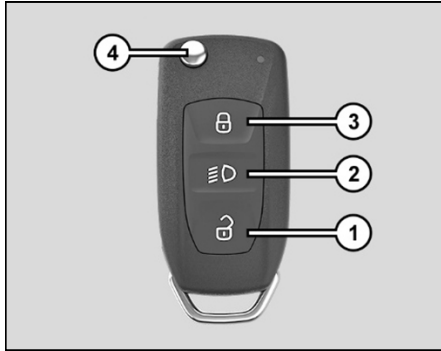

1. Unlock
2. Approach Light /follow me
3. Lock
4. Key blade in / out button

1. Unlocking All Doors

To unlock all doors, press unlock push-button (1) once. Unlocking will be confirmed by single flash of turn indicators.

2. Approach Light / Follow Me

Press approach light button (2) once, low beams, position lamps and roof lamp will turn 'ON'. For XM and entry variants, only Position lamp will turn ON. This feature helps to find and reach the parked vehicle or to reach home in dark/ cloudy condition after parking. To switch 'OFF' the approach lights, press and release the same button or it automatically turns 'OFF' after approx. 30 seconds.

3. Locking All Doors

To lock all doors, press lock push-button (3) once. Locking will be confirmed by two flashes of turn indicators.

If lock button is pressed on the remote key with any door open, locking-unlocking takes place with audible warning indicators do not flash.

4. Folding Key Blade In / Out

Press button (4) to flip out the key blade. For folding, press the button (4) and fold the key blade inside.



NOTE

Key Blade should not be folded without pressing the button. Also, it should not be forced in any direction apart from folding direction to avoid damage to Flip Mechanism.

OPENING AND CLOSING

FLIP KEY FEATURES

Vehicle Search

Vehicle is in locked condition, if lock button on remote key is pressed the turn indicators of vehicle flashes 4 times.

Automatic Activation Of Immobilizer

If key is removed from ignition, the engine will be immobilized automatically even if you forget to lock the vehicle.

Auto Locking / Unlocking Of Doors / Auto Relock

Vehicle doors get automatically locked when all doors are closed and the vehicle speed crosses 10 kmph.

When ignition key is taken out all the doors get automatically unlocked.

Also, when unlocked with remote key and if no door is opened within 30 seconds, vehicle doors get automatically locked.

Anti-grab / Anti-scan Coding

The remote control set of this security system is protected against the use of devices called 'scanners' and 'grabbers' which can record and reproduce some types of remote codes.

Sleep Mode

If remote key is not used for more than a week then its functionalities will turn to sleep mode. In such a case, to activate the remote key functionalities, open the door mechanically with the key blade.

NOTE

In case any button of the key is accidentally pressed for more than 20 seconds, the remote stops functioning till the time the button is pressed. The LED on the Remote also stops glowing. The function of the remote gets reinstated immediately when the user stops pressing the push button of remote.

Important

Don't operate Unlock push-button of remote while in the vicinity of your vehicle, as it could lead to an unintentional unlocking your vehicle.

Don't use discharged batteries in remote, as it could damage the remote.

For battery replacement procedure refer maintenance section.

Don't remove the battery connection of the vehicle while the vehicle has been locked by remote.

DOORS

Option I - Door Lock And Unlock With Key (if equipped)

The front doors can be locked or unlocked from outside using the key blade.

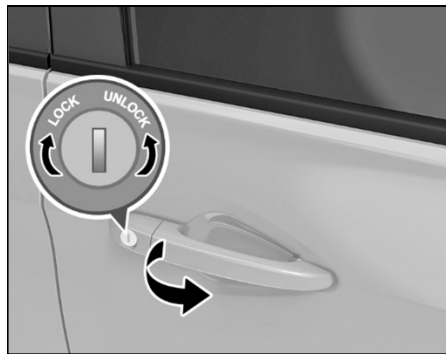

Insert the key in the slot and turn it clockwise to lock and anticlockwise to unlock the door.

Manual Operation Of Central Door Locking / Unlocking

All doors can be locked / unlocked operating driver door using either key blade from

outside or knob from inside.

Locking Without A Key From Inside

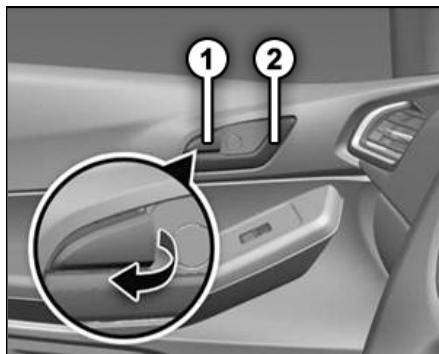

All the doors can also be locked from inside by pressing knob (1) on driver door and independently on other doors respectively.

Opening The Doors From Inside

All doors can be opened from inside. To open, pull the door opening knob (1) and then lever (2).

All doors can be opened from inside. To open, pull the door opening lever. All doors can be unlocked by pulling the inside re-

lease lever to the intermediate position. When it is further articulated will unlatch the door and can be opened.

OPENING AND CLOSING

WINDOWS

Power Windows (If equipped)

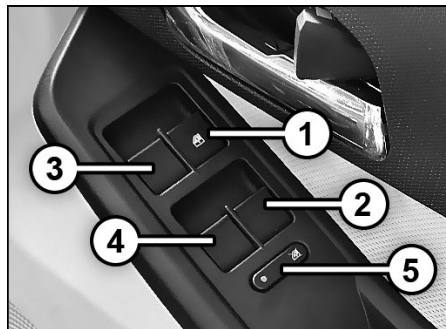

1. Front Window Winding Switch (Right)
2. Rear Window Winding Switch (Right)
3. Front Window Winding Switch (Left)
4. Rear Window Winding Switch (Left)
5. Inhibit Switch

Window glasses on all four doors can be operated by switches provided on the main control panel located on the driver's arm rest. They work only when the key is in the 'IGN ON' position.

i NOTE

Power windows can be operated for 30 seconds in 'IGN OFF' and 'KEY OUT' positions, provided the doors are closed.

Express Down (if equipped)

Window glasses can be opened by a single long press of the switch. Express down feature is provided for the driver's door only.

Individual Switches

Individual window winding switches have been provided on the front passenger and rear doors.



Glasses are wound up or down by pulling or pressing the switch.

⚠ WARNING

While raising the glass, take care to avoid fingers/hands getting trapped between glass and the door frame.

Inhibit Switch



When switch is pressed, amber light turns 'OFF'. The individual switches provided on rear and front passenger door can be operated. It can also be operated from the switches on driver's arm rest.

When switch is depressed amber light turns 'ON'. The individual switches provided on rear and front passenger door cannot be operated. Still it can be operated from the switches on driver's arm rest.

WARNING

- If children operate the windows they could get trapped, particularly if they are left unsupervised. There is a risk of injury.
- Activate the window inhibit feature. When children are travelling. When leaving the vehicle, always take the key with you and lock the vehicle. Never leave children unsupervised in the vehicle.

Manual Window Winding (If equipped)

Use window winder handle for lowering or raising up window glasses manually where power windows are not provided.

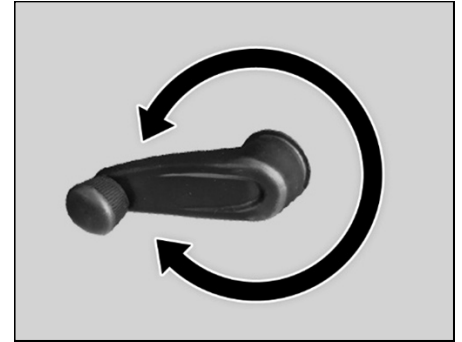

OPENING AND CLOSING

OPENING THE BONNET

Opening

1. Make sure that the engine is switched off and vehicle is in neutral gear with the parking brake applied.
2. Pull the bonnet release lever. The bonnet will pop up slightly.



3. Lift the bonnet slightly and with your finger and slide the secondary lock lever located under the center of the bonnet.



i NOTE

Make sure that the wiper arms are not raised before you lift up the bonnet to avoid damaging the wiper arms and the bonnet.

4. Lift the bonnet up. Pull the bonnet stay rod from its clip and put the free end into the slot provided on frame.

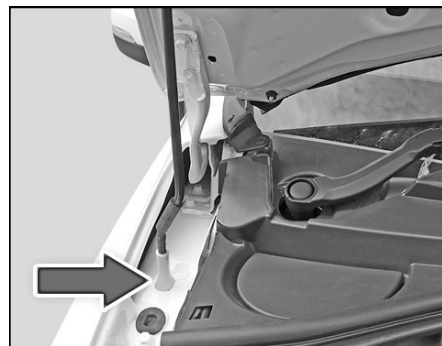
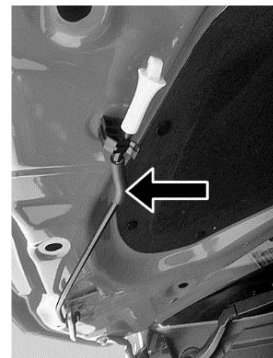

WARNING

- The stay rod can be hot enough to burn your finger right after driving. Touch the rod after it becomes cool enough.
- Put the stay rod into the hole correctly. If the rod drops off, your body may be caught below the bonnet.

Closing

1. To close the bonnet, hold the bonnet by one hand, disengage the stay rod and clamp it back properly.
2. Lower the bonnet close to the bumper, then let it drop down.

WARNING

Make sure that the bonnet is correctly locked or it can fly up unexpectedly when you drive.

TAIL GATE OPENING

NOTE

Some variants may have multiple options.

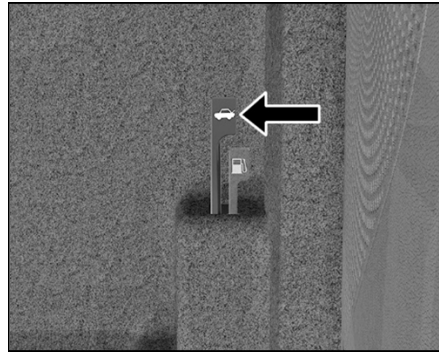

Trunk lid opening Lever is located on the below right hand side of the driver seat. Lift the lever to unlock trunk lid.

FUEL LID

Option I (if equipped)

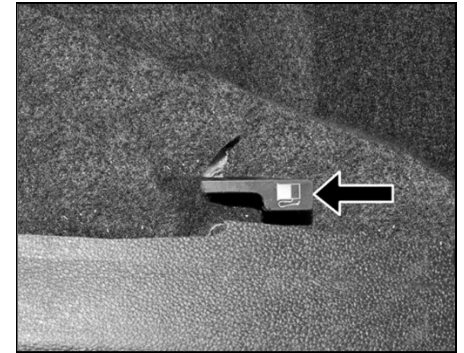

OPENING AND CLOSING

Option II (if equipped)

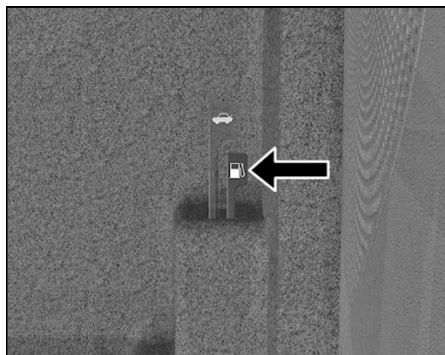

To release the fuel flap, pull the lever located at the right hand side below the driver seat.

For opening, open the fuel cap, turn it counter clockwise.



For closing, Place the fuel cap back into the filler pipe, and rotate in clockwise direction until click sound is heard and then gently push the fuel flap till it gets locked.

WARNING

- Fuel vapor is extremely hazardous. Always switch 'OFF' the engine before refueling and never refill near sparks or open flames. Do not use cell phone when you fill fuel.
- Do not continue adding fuel after the automatic shut 'OFF' function is op

erated if it is equipped on the fuel station. Overfilling the fuel tank could damage the fuel system.

NOTE

- To fill up the fuel, the Engine must be stopped by turning OFF the Ignition Key / Start-Stop button.
- Remove the fuel filler cap slowly, and wait for any hissing to stop. The fuel may be under pressure and may spray out.
- If fuel cap needs replacement, make sure that it is replaced by a genuine cap at the TATA MOTORS authorized service center.
- Ensure that engine is switched OFF while filling fuel.

COCKPIT (MT)

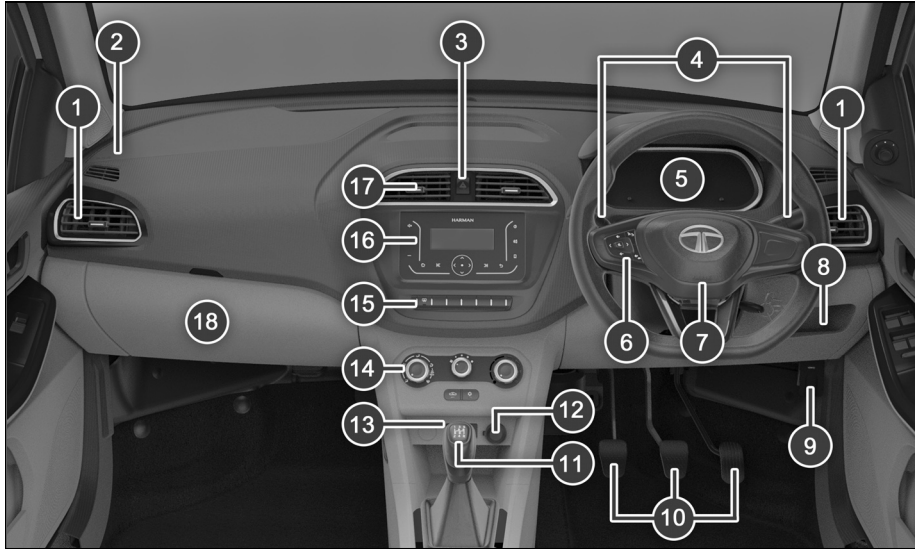

1	A.C. Air vent (Side)
2	Air Bag (PAB)
3	Hazard Warning Switch
4	Combi-Switch
5	Instrument Cluster
6	Steering Wheel Switches (if equipped)
7	Air Bag (DAB)
8	Driver Side Coin Box
9	Bonnet Opening Lever
10	Controls
11	Gear Shift Lever
12	Power Socket
13	USB Port
14	Manual HVAC
15	Fascia Switches
16	Infotainment Display
17	Center AC Vent
18	Glove Box

The above shown image is for reference purpose only.

DASHBOARD AND FEATURES

DIGITAL DISPLAY (4" INCH) (IF EQUIPPED)

4" Inch Display Option I

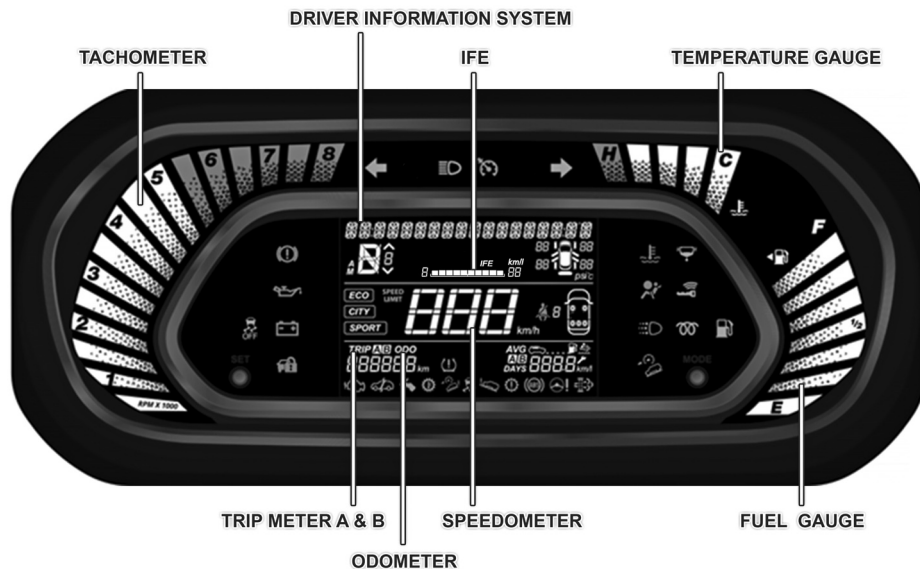

Note: All parameters may or may not be applicable to your vehicle

4" Inch Display Option II (if equipped)

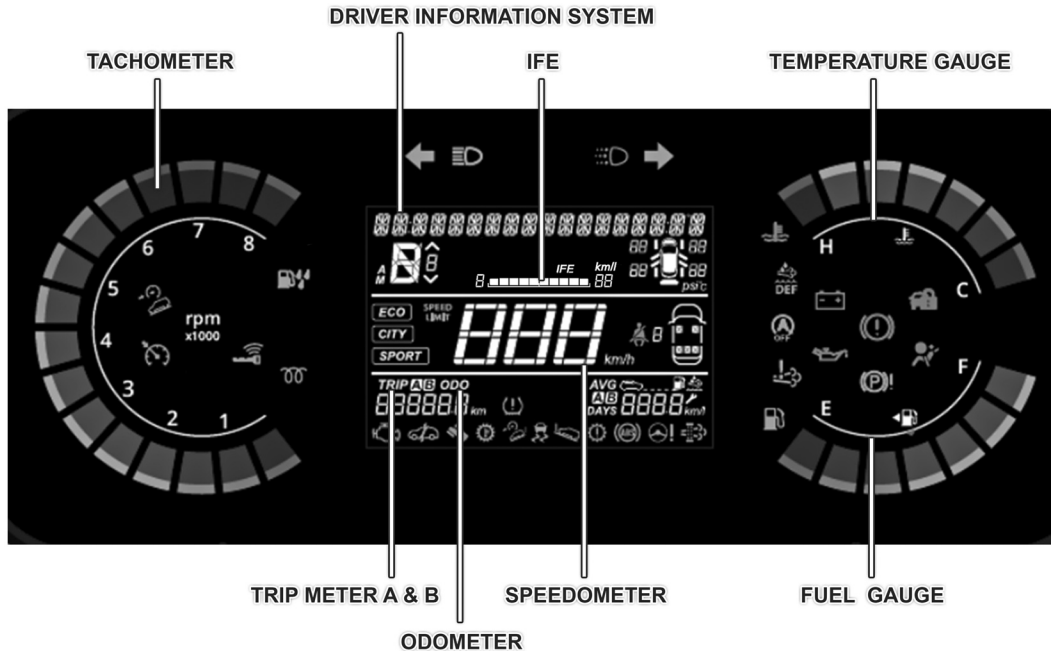

Note: All parameters may or may not be applicable to your vehicle

DASHBOARD AND FEATURES

Gauge	Information	Note/Warning
Speedometer	The Speedometer Indicates the actual vehicle speed in km/h	<ul style="list-style-type: none"> At every key IN and Ignition ON, the speedometer Bar moves to MAX and return to '0' position. This is welcome strategy and self-check feature
Tachometer	Tachometer indicates the engine speed in revolutions per minute.	<ul style="list-style-type: none"> Whenever engine is accelerated beyond safe RPM, tachometer Bar Indication turns RED. In such case, reduce the engine RPM immediately. Never drive the vehicle with engine in high RPM. This may cause severe engine damage.
Odometer	Odometer Indicates distance traveled by vehicle.	<ul style="list-style-type: none"> The odometer reading does not return to 0 when maximum value is reached, the display will freeze to maximum value.
Fuel Gauge	<p>When the ignition switch is in "ON" position, fuel gauge gives an approximate indication of the amount of fuel in the fuel tank. "F" stands for full and "E" stands for Empty.</p> <p>When fuel in the tank is near to empty position, low fuel warning telltale turns Amber. Refill the tank as soon as possible.</p> <p>At every key in and Ignition ON, Fuel Gauge Bar move to F and come back to E position. This is welcome strategy.</p>	<ul style="list-style-type: none"> On inclines, curves, during braking and sudden acceleration due to the movement of fuel in the tank, the fuel level display may fluctuate or the low fuel level warning lamp may turns ON/OFF earlier or delayed than usual. When the ignition switch is in "ON" position, this gauge gives an approximate indication of the amount of fuel in the fuel tank and it takes few seconds to stabilize after the ignition is turned ON.





Gauge	Information	Note/Warning
Temperature Gauge	<p>When the ignition switch is in the “ON” position, this gauge indicates the engine coolant temperature. The indicator should be within normal, acceptable temperature range i.e., between “H” and “C”. If the indicator approaches “H”, overheating is indicated by red LED bar in case of 4”.</p> <p>The RED bar and High Coolant temp warning telltale indicates overheating that may damage the engine. Continuing to drive the vehicle when engine overheating is indicated can result in severe engine damage or fire.</p>	<ul style="list-style-type: none"> • If the coolant temperature reading is very high, The Engine coolant temperature telltale flashes with an audible buzzer. • In this case, stop the vehicle, switch ‘OFF’ the engine and cool it down for some time. Contact a nearest TATA MOTORS Authorised Service Center immediately for rectification.
Instantaneous Fuel Economy	<p>It indicates fuel economy of current drive when Ignition is turned ‘ON’.</p> <p>The display does not show actual value unless vehicle is moving.</p>	<ul style="list-style-type: none"> • IFE will vary frequently as per driving pattern. • The IFE display does not show Fuel Economy of last drive. • The indication on the display may be delayed if fuel consumption is affected by driving pattern.
Trip Meter A & B	<p>Trip Meter A Trip A Indicates distance traveled by vehicle since last reset within the range of 0 km to 9999.9 km with the resolution of 0.1 km.</p> <p>Trip Meter B Trip B Indicates distance traveled by vehicle since last reset within the range of 0 km to 9999.9 km with the resolution of 0.1 km.</p>	<ul style="list-style-type: none"> • Trip A can be RESET to 0 by long press Set switch when display is in a TRIP A mode. • Trip B can be RESET to 0 by pressing Set switch when display is in a TRIP B mode.

DASHBOARD AND FEATURES

Driver Information System

Driver Information	System Image	Description
Service reminder		<p>There are two types of service reminder</p> <p>By Kms: The service reminder shall come at every 10000 kms and it's telltale shall be pop up before 500kms of due (i.e. 10000-500=9500km) and it shall be subtracted from the distance travelled.</p> <p>By Days:</p> <p>The service reminder shall come at every 365 days, and it shall be pop up before 30 days of due time(i.e. 365-30=335 days) and it shall be subtracted from the days crossed.</p> <p>By Kms overdue</p> <p>The service reminder overdue shall come if the due km is crossed and it's text alert shall be displayed in every IGN ON.</p> <p>By days overdue</p> <p>The service reminder overdue shall come if the due days is crossed and it shall be displayed in every IGN ON.</p> <p>Note:</p> <p><i>Take it to the authorized TATA service station between the regular intervals of service reminder notification Days/Km in the screen and do not reset the service reminder before the service, and it shall be reset by the Authorized person during the service</i></p> <p>Reset Process:</p>



DASHBOARD AND FEATURES

Driver Information	System Image	Description
		<p>User can select Service Reminder DIS Screen by pressing 'Mode' switch</p> <p>After shifting to service page, user can reset the Service Reminder by long press(More than 15 Sec) of 'Set' button. After long press Service Reminder due Kilometers shall start blinking, this time user must release the 'Set' button and again Long press 'Set' button unless service reminder gets reset.</p>
Gear Recommendation		<p>Up or down arrow will be displayed on DIS to shift a gear up or down.</p> <p>No arrow shall be displayed when the selected gear is as per the Vehicle dynamics.</p> <p>NOTE: Following the recommended Gear shall result into a better Fuel Economy.</p>
Door Ajar		<p>All four door and trunk lid are indicated independently when respective door or trunk lid is open.</p> <p>NOTE: If any other door is open roof lamp will be 'ON' provided that roof lamp switch is on door position.</p>
Door Ajar		<p>This warning will be indicated when driver door is open.</p> <p>NOTE: If any other door is open roof lamp will be 'ON' provided that roof lamp switch is on door position</p>
Outside Ambient Temperature		<p>Displays outside ambient temperature in °C.</p> <p>NOTE:The temperature sensor is in the front bumper of the vehicle, therefore the temperature reading can be affected by heat reflection from the road surface, engine</p>

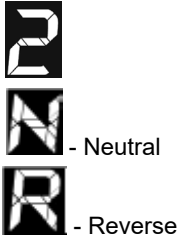

DASHBOARD AND FEATURES

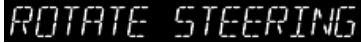
Driver Information	System Image	Description
		<p>heat and the exhaust from surrounding traffic. This can cause an incorrect temperature reading when speed is under low speeds or when stopped.</p> <p>If display shows ' - - ', take your car to TATA MOTORS Authorised Service Center.</p>
Clock		<p>When the ignition switch is in the "ON" position, it shows the time 12 Hours or in 24 Hours mode as per selection.</p> <p>Note: 1. You can do clock settings in Infotainment system when Infotainment is present in the vehicle. 2. Whenever the battery terminals or related fuses are disconnected and reconnected user must reset the clock time. This feature is available when ignition switch is in ON position.</p>
Current Gear Indication		<p>Current gear engaged by the transmission shall be displayed on DIS. This feature is applicable to Manual transmission variant.</p> <p>In case of Manual transmission, the gear display is as per the User selection.</p>

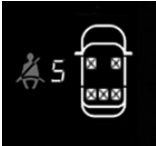



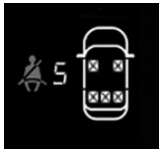



DASHBOARD AND FEATURES

Driver Information	System Image	Description
		<p>Note: If  is displayed, it means 'Fault' condition. In such case, take vehicle to TATA MOTORS Authorised service Center. In case of Manual Transmission the Gear number will be displayed when the clutch is fully released.</p>
Rotate Steering		<p>"ROTATE STEERING" text warning comes 'ON' for 4 seconds when electronic steering column is in locked state. Rotate Steering slightly (left or right) to unlock it.</p> <p>Note: If text warning "ROTATE STEERING" is displayed even after rotating the steering, it means 'Faulty' condition. In such case, take vehicle to TATA MOTORS Authorised Service Center.</p>
Transmission Overheat Indication for DCA feature (if Equipped)		<p>Illuminates momentarily when ignition is switched 'ON'. Illuminates continuously when there is a High Temperature of Dual Clutch Transmission System. Contact a TATA MOTORS Authorised Service Center immediately.</p>
Front Seat Belt Indicator (if equipped)		<p>If driver and Passenger is present and seat belt is not buckled and IGN is ON then Telltale will be ON as initial warning with No audio chime.</p> <p>If any driver and Passenger seat belt remains unbuckled and vehicle speed goes around 15 km/ hr, then Seat belt</p>



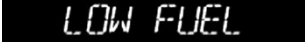

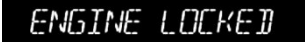



DASHBOARD AND FEATURES

Driver Information	System Image	Description
		<p>telltale will also start flashing along with audio alarm during Final Warning.</p> <p>Note: Once the seatbelt are fastened the buzzer and warning lamp turns OFF. Seatbelt reminder remains OFF when reverse gear is engaged.</p>
Rear Seat belt Indicator (if equipped)		<p>The seat belt warning lamp turns on in case seat is occupied and seatbelt is not buckled. Warning lamp will be ON continuously.</p> <p>When reverse gear is engaged and seat is occupied and seatbelt is unbuckled, only visual warning will be given. If reverse gear is disengaged, thereafter forward gear is re-selected and vehicle speed is below 10Km/h, visual warning turns ON and above 10 kmph audio warning start alarming for 35 sec.</p>
Gear Display (For DCA if equipped)		<p>Current gear engaged by the transmission shall be displayed on Display Screen along with D. This feature is applicable to Dual clutch transmission variant.</p> <p>Note: If F is displayed, it means 'Fault' condition. In such case, take vehicle to a TATA MOTORS Authorised service Center.</p>
Key batt low (for PEPS, if equipped)		<p>"KEY BATT LOW" text warning comes 'ON' for 4 seconds when UID key battery is low.</p>

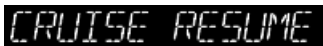





DASHBOARD AND FEATURES

Driver Information	System Image	Description
Key out of range (for PEPS, if equipped)		"KEY OUT OF RANGE" text warning comes 'ON' for 4 seconds when UID key is not inside the vehicle.
Press Clutch (for PEPS, if equipped)		"PRESS CLUTCH" text message comes 'ON' for 4 seconds when clutch is not pressed to crank the vehicle. Note: This text warning is applicable for MT vehicle.
Press Brake (for PEPS, if equipped)		"PRESS BRAKE" text message comes 'ON' for 4 seconds when BRAKE is not pressed to crank the vehicle. Note: This text warning is applicable for AMT/DCT vehicle.
Service due		"SERVICE DUE" text warning comes 'ON' for 4 seconds when service is overdue.
Low brake fluid		"LOW BRAKE FLUID" text warning comes 'ON' for 4 seconds when brake fluid is low.
Low fuel		"LOW FUEL" text warning comes 'ON' for 4 seconds when low fuel warning telltale comes 'ON' and fuel level is low.
Take a break		"TAKE A BREAK" text warning comes 'ON' for 4 seconds when driver drives continuously for prolonged duration. Note: "TAKE A BREAK" text warning comes 'ON' for 4 seconds again with specific duration if vehicle is not stopped and continuously driven.
Engine locked		"ENGINE LOCKED" text warning comes 'ON' for 4 seconds when engine is unable to crank.
Unable to resume (if equipped)		"UNABLE TO RESUME" text warning comes 'ON' for 4 seconds when cruise function is unable to resume/activate.

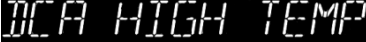

DASHBOARD AND FEATURES

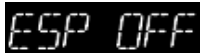
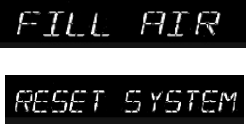
Driver Information	System Image	Description
Cruise off (if equipped)		"CRUISE OFF" text warning comes 'ON' for 4 seconds when cruise function is deactivated.
Cruise cancelled (if equipped)		"CRUISE CANCELLED" text warning comes 'ON' for 4 seconds when cruise function is cancelled by user.
Cruise resume (if equipped)		"CRUISE RESUME" text warning comes 'ON' for 4 seconds when cruise function is resume.
Cruise Override (if equipped)		"CRUISE OVERRIDE" text warning comes 'ON' for 4 seconds when cruise function is override by user.
Happy Birthday (if equipped)		"HAPPY BIRTHDAY" text comes 'ON' for 4 seconds on owner's birthday.
HDC Active (if equipped)		"HDC ACTIVE" text warning comes 'ON' for 4 seconds when hill descent control function is active.
HDC deactivate (if equipped)		"HDC DEACTIVE" text warning comes 'ON' for 4 seconds when hill descent control function is deactivated.
TPMS ERROR VISIT SERV CENT - Text Warning		TPMS ERROR VISIT SERV CENT" text warning comes 'ON' for 4 seconds when pressure monitoring system malfunction
TURN IGN OFF AND ON AGAIN - Text Warn- ing (if equipped)		"TURN IGN OFF AND ON AGAIN" text warning comes 'ON' for 4 seconds when DCT Auth failure warning is present.



DASHBOARD AND FEATURES

Driver Information	System Image	Description
DCA FAULT - Text Warning (if equipped)		"DCA FAULT" text warning comes 'ON' for 4 seconds when failure detected in DCT System
STAY IN D FOR 20 S - Text Warning (if equipped)		"STAY IN D FOR 20 S" text warning comes 'ON' for 4 seconds to inform user to stay vehicle in Drive mode for 20sec
DCA HIGH TEMP - Text Warning (if equipped)		"DCA HIGH TEMP" text warning comes 'ON' for 4 seconds when DCT temp reached above threshold value
SHIFT DENIED - Text Warning (if equipped)		"SHIFT DENIED" text warning comes 'ON' for 4 seconds when user selected gear denied from DCT system
AUTO MODE -Text Warning (if equipped)		"AUTO MODE" text message comes 'ON' for 4 Seconds when it is activated in DCT system.
ESP OFF		"ESP OFF" text message comes 'ON' for 4 seconds when ESP is made off.
FILL AIR RESET SYSTEM- Text Warning (if equipped)		"FILL AIR RESET SYSTEM" text message comes 'ON' for 4 seconds when Tyre pressure Low Detected by iTPMS.
TPMS - Tyre Pressure Monitoring System (if equipped)		Tyre pressure information for individual tyre with pressure values will be displayed with "psi" unit on DIS if tyre pressure is within defined range.

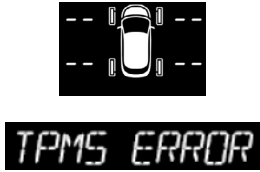

DASHBOARD AND FEATURES

Driver Information	System Image	Description
	 <p>The image shows a car icon with pressure values: 23 (top-left), 32 (top-right), 32 (bottom-left), and 32 (bottom-right). The unit 'psi' is at the bottom. Below the car icon are two black rectangular boxes with white text: 'CHECK TYRE' and 'PRESSURE'.</p>	<p>Tyre pressure value of respective Tyre and Tyre symbol will blink if Tyre pressure is low. Tyre pressure values will be displayed with “psi” unit for remaining tyres “CHECK TYRE“ for 1s and “PRESSURE” for another 1s text warning comes ON for 2cycle within 4secs if Tyre pressure is LOW.</p>
TPMS - Tyre Pressure Monitoring System (if equipped)	 <p>The image shows a car icon with pressure values: 32 (top-left), 32 (top-right), 32 (bottom-left), and 38 (bottom-right). The unit 'psi' is at the bottom. Below the car icon are two black rectangular boxes with white text: 'CHECK TYRE' and 'PRESSURE'.</p>	<p>Tyre pressure value of respective Tyre and Tyre symbol will blink if Tyre pressure is High. Tyre pressure values will be displayed with “psi” unit for remaining tyres. “CHECK TYRE“ for 1s and “PRESSURE” for another 1s text warning comes ON for 2 cycle within 4 secs if tyre pressure is HIGH.</p>
	 <p>The image shows a car icon with pressure values: 'AL' (top-left), 30 (top-right), 32 (bottom-left), and 'AL' (bottom-right). The unit 'psi' is at the bottom. Below the car icon are two black rectangular boxes with white text: 'CHECK TYRE' and 'PRESSURE'.</p>	<p>Text warning “AL” near to respective tyre and tyre symbol will blink if air is leakage. Tyre pressure values will be displayed with “psi” unit for remaining tyres. “CHECK TYRE” for 1s and “PRESSURE” for another 1s text warning comes ON for 2 cycle within 4 secs if air is leakage.</p>



DASHBOARD AND FEATURES

Driver Information	System Image	Description
<p>TPMS Tyre Pressure Monitoring System (if equipped)</p>	 <p>The image shows a top-down view of a car with four tyre symbols. The top-left tyre symbol has 'HI' above it and '30' below it. The top-right tyre symbol has '31' above it and '32' below it. Below the car icon, the text 'HIGH TYRE' is displayed on the first line and 'TEMPERATURE' on the second line.</p>	<p>Text warning "HI" near to respective tyre and tyre symbol will blink if tyre temperature is High. Tyre temperature values will be displayed with °C unit for remaining tyres. "HIGH TYRE" for 1s and "TEMPERATURE" for another 1s text warning comes ON for 2 cycle within 4 secs if tyre temperature is High.</p>
<p>TPMS Tyre Pressure Monitoring System (if equipped)</p>	 <p>The image shows a top-down view of a car with four tyre symbols. Each tyre symbol has two dashes "--" above and below it. Below the car icon, the text 'TPMS ERROR' is displayed.</p>	<p>Text warning "--" near to respective tyre and tyre symbol will blink if sensor has fault/missing. Tyre pressure values will be displayed with "psi" unit for remaining tyres. "TPMS ERROR" text warning comes ON for 4 seconds when TPMS sensor has fault. Note: If text warning "--" is displayed, it means "fault/missing" condition. In such case, take vehicle to TATA MOTORS Authorised Service Center</p>
<p>TPMS Tyre Pressure Monitoring System (if equipped)</p>	 <p>The image shows a top-down view of a car with four tyre symbols. Each tyre symbol has two dashes "--" above and below it. Below the car icon, the text 'TPMS ERROR' is displayed.</p>	<p>Text warning "—" near to all the tyre and tyre symbol will blink if TPMS system has fault/missing. "TPMS ERROR" test warning comes ON for 4 seconds when TPMS system has fault. Note:</p>

DASHBOARD AND FEATURES

Driver Information	System Image	Description
Instantaneous fuel economy (IFE)		<p>INST FE shall vary frequently as per driving pattern. The INST FE display does show Fuel Economy of last drive. It indicates Instantaneous Fuel economy of current Drive when Ignition is turned ON. The display does not show actual value unless vehicle is moving.</p> <p>The indication on the display may be delayed if fuel consumption is affected by driving pattern.</p> <p>User can change the INST FE unit as km/l or Miles per Gallon (MPG UK) using SET and MODE buttons. 'MPG' is applicable for Export variant only.</p> <p>For km/l setting, the indicated maximum value of INST FE is 30 km/l. No more than 30 shall be indicated on the display even if the actual INST FE is higher than 30 km/l. For MPG setting, the indicated maximum value of INST FE is 80 MPG. No more than 80 shall be indicated on the display even if the actual INST FE is higher than 80 MPG.</p>
Distance To Empty		<p>It indicates approximate distance in 'km' that your vehicle can travel with available fuel in tank. DTE values may vary significantly based on driving conditions, driving habits, and condition of the vehicle. It is an estimate value of the available driving distance. The DTE will update with new value when fuel is added more than 7 litre at a time.</p>

DASHBOARD AND FEATURES

Driver Information	System Image	Description
		<p>If low fuel warning light turns 'ON', fill the fuel tank immediately regardless the value of displayed DTE.</p> <p>If vehicle is not on level ground or negative of battery has been disturbed, the DTE function may not operate correctly.</p> <p>Note: If DTE is displayed as '—', take vehicle to TATA MOTORS Authorised Service Center.</p>
Full Isolation iTPMS (If equipped)		<p>Text warning "LO" near to respective tyre and tyre symbol will blink if tyre Pressure is Low.</p> <p>"FILL AIR" for 1s and "RESET SYSTEM" for another 1s text warning comes ON for 2cycle within 4secs if tyre Pressure is Low.</p>
TATA MOTORS		<p>"TATA MOTORS" text warning comes 'ON' for 4 seconds when ignition is turned 'ON'.</p> <p>This is part of the welcome strategy.</p>

Driver Information System (DIS) Setting (if equipped)

Screen Setting

Option I:

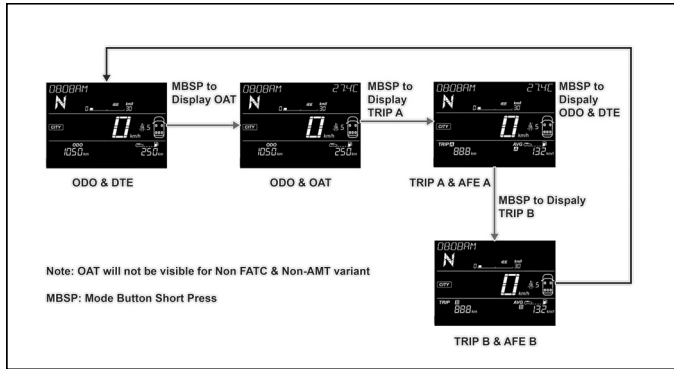

Option II (if equipped):

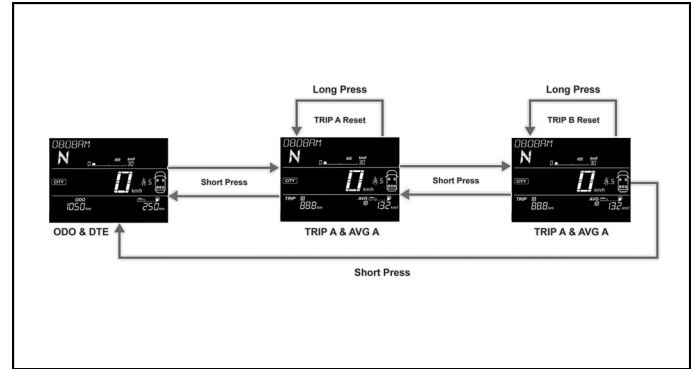

DASHBOARD AND FEATURES

Illumination And Clock Setting

Option I:

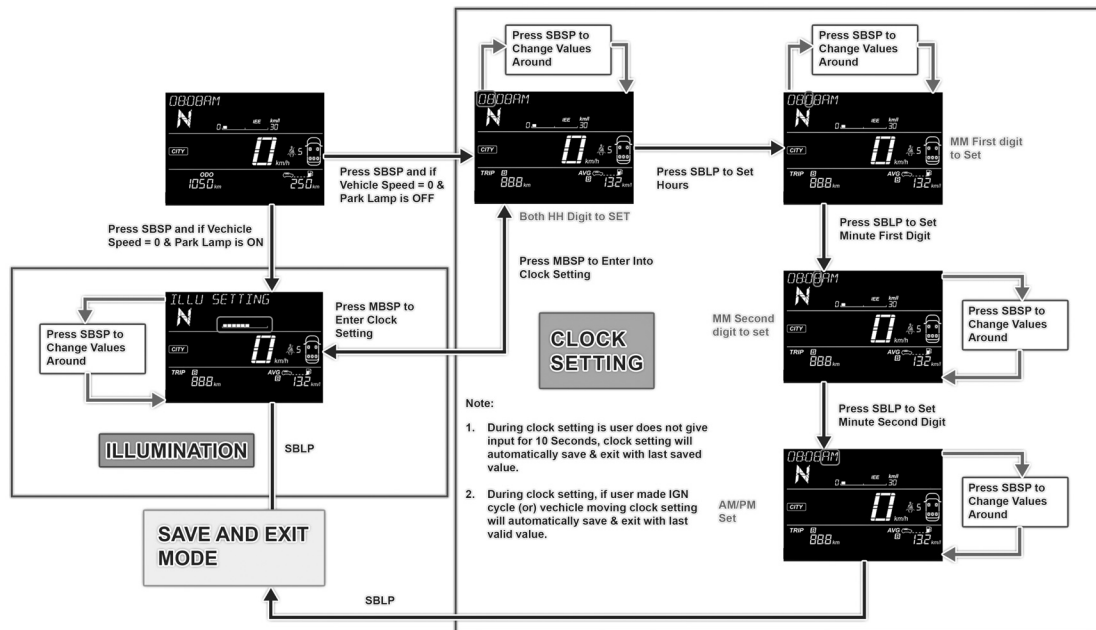

Option II (if equipped):

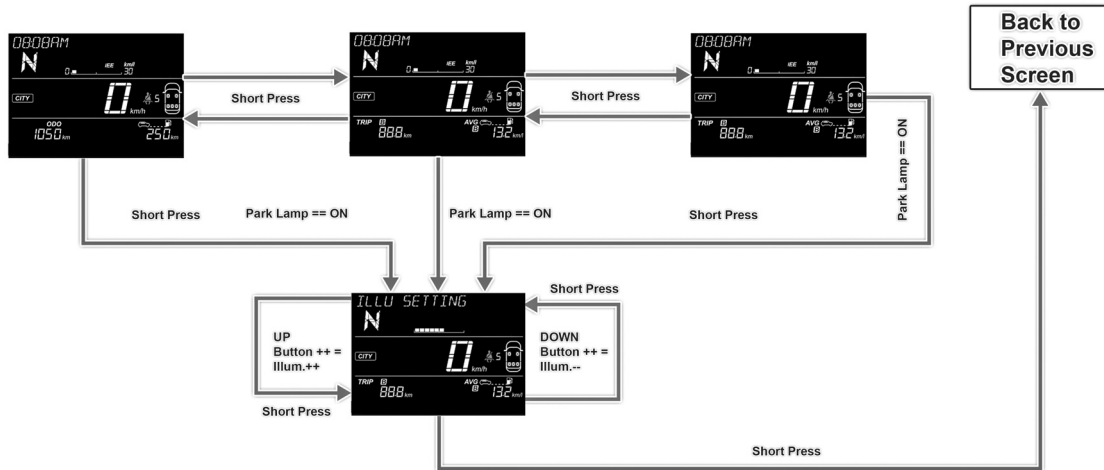

DASHBOARD AND FEATURES

Clock Setting (if Equipped)

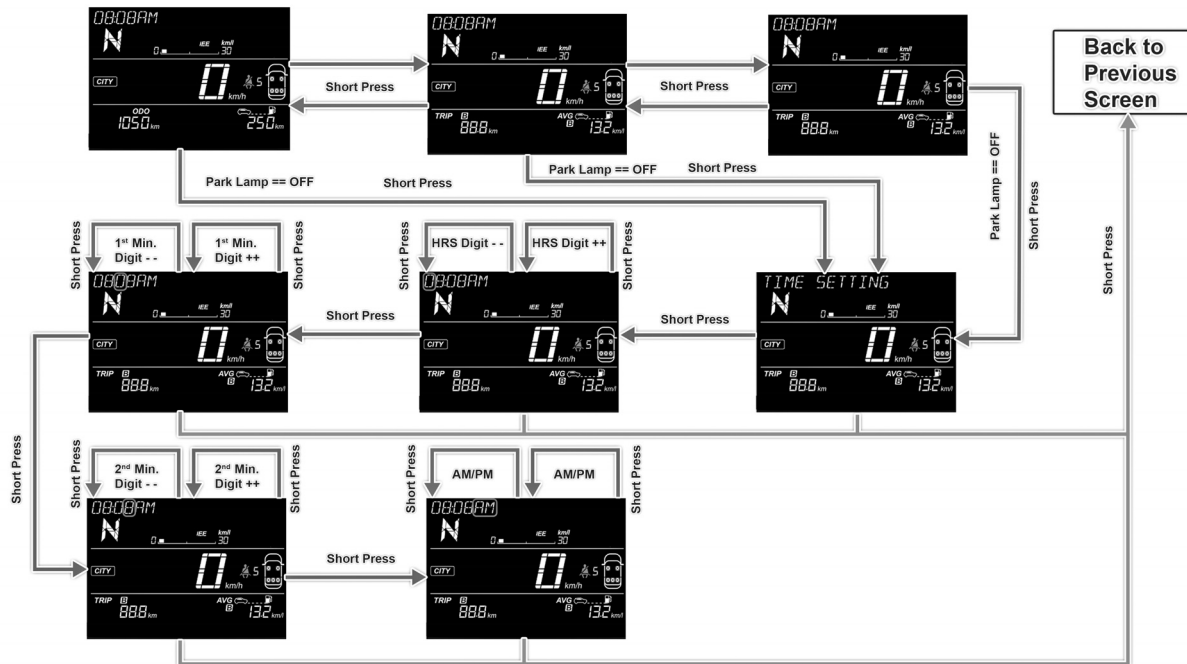

Service Reminder Reset

Service Reminder Reset when due by Kilometre:

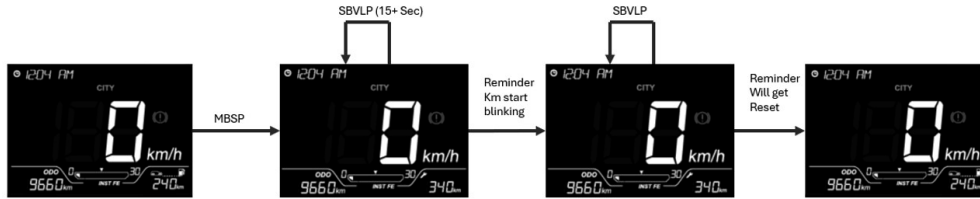



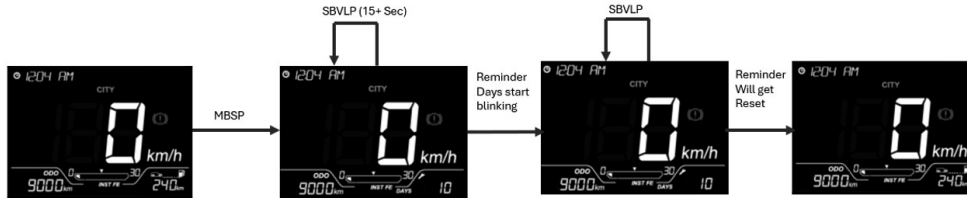

Service Reminder Reset when due by Days:







SBVLP - Set Button Very Long Press
MBSP - Mode Button Short Press

DASHBOARD AND FEATURES





TELL TALES

Warning Lamps	Color	Indicator	Remarks
Malfunction Indication Lamp (MIL)	Amber		<ol style="list-style-type: none">1. The lamp comes on when ignition is switched 'ON'. Once engine is started, it turns 'OFF'.2. It remains 'ON' for any engine related fault that may increase emission levels of the vehicle beyond the regulatory norms. Contact the TATA MOTORS Authorized Dealer/Service Center for rectification.
Check Engine Lamp	Amber		<ol style="list-style-type: none">1. The lamp comes on when ignition is switched 'ON'. Once engine is started, it turns 'OFF'.2. Illuminates continuously if a fault arises in Engine Management System. Contact the TATA MOTORS Authorized Dealer/Service Center.
Immobilizer (if equipped)	Red		<ol style="list-style-type: none">1. The lamp comes on when the system disables the engine start if the original key is not used.2. Lamp blinks: Vehicle is in immobilized condition when key is not inserted.3. Lamp ON: Problem with key/system. Contact TATA MOTORS Authorized Dealer/Service Center.4. Lamp OFF: Normal condition (Authenticated user) and engine will start.
Turn Signal	Green		<p>Indicates direction indicated by the turn signal.</p> <p>While you operate the left/right turn indicator, the turn signal blinks along with the buzzer (when ignition is 'ON'). The direction indicator arrow on the instrument cluster flashes along with the selected external indicator lights. Both tell-tale lights will blink simultaneously when the hazard switch is pressed irrespective of whether the ignition ON or OFF. A tick-tock sound will be heard in both cases.</p>







DASHBOARD AND FEATURES

Warning Lamps	Color	Indicator	Remarks
High Beam	Blue		The lamp comes on when the high beam headlamps are switched 'ON' or flashed.
Low Oil Pressure indicator	Red		<ol style="list-style-type: none"> 1. The lamp comes on when ignition is switched 'on' and goes 'off' once required engine oil pressure is developed after starting the engine. 2. If the low oil pressure indicator does not glow or remains 'on' when the engine is running, it indicates a fault either in the electrical circuit or in the lubrication system. 3. Stop the vehicle safely as soon as possible and turn off the engine. Restart the engine to check whether the issue continues. If yes, turn off the engine immediately and contact the nearest TATA MOTORS Authorized Service Centre to rectify the issue. <p>Caution: Running the engine with the engine oil pressure warning lamp glowing could cause serious damage to the engine.</p>
Battery charging	Red		<p>The lamp comes on when ignition is switched 'ON'. Once engine is started, it turns 'OFF'.</p> <p>If it remains 'ON' while the engine is running, it indicates that the battery is not getting charged or having the lower charge. In such cases, attempt to charge the battery with 3000 engine rpm for 15 min and see if battery telltale goes off after one ignition ON- OFF. Even after 15 minutes, charging the battery telltale keeps 'ON' then switch off all unnecessary electrical equipment and contact the nearest TATA motors authorized service center.</p>
Airbag status	Red		The lamp comes on when ignition is switched 'ON' and goes 'OFF'. If it continuously blinks then contact the TATA MOTORS Authorized Service Center.





DASHBOARD AND FEATURES

Warning Lamps	Color	Indicator	Remarks
Park Brake / Brake Fluid Low / EBD malfunction	Red		The lamp comes on momentarily when ignition is switched 'ON'. Once parking brake is released, it turns 'OFF'. If it remains 'ON', then it indicates: <ol style="list-style-type: none"> 1. Brake fluid level is low. 2. Park brake is applied. 3. EBD malfunctioning.
AMT Fault (if equipped)	Amber		Illuminates momentarily when ignition is switched 'ON'. Illuminates continuously when there is a fault in Automatic Manual Transmission system. Contact a TATA MOTORS authorized Service Centre immediately.
High Coolant Temperature	Red		The lamp comes on when ignition is switched 'ON'. Once engine is started, it turns 'OFF'. If the engine overheats due to higher coolant temperatures, this indicator blinks along with an audible buzzer. Contact your nearest TATA MOTORS authorized service Centre immediately. When the engine coolant temperature reaches the maximum limit, the tell-tale lights blink with a RED colour and you will hear an audio warning. Note: Do not remove the radiator pressure cap from the radiator when the engine is hot. Do not restart the engine until the problem has been duly attended.
ABS	Amber		The lamp comes on when ignition is switched 'ON'. Once engine is started, it turns 'OFF'. The lamp remains on if there is any malfunction in ABS. Normal braking system will be operational without assistance of ABS. Contact the TATA MOTORS Authorized Dealer/Service Center immediately.

DASHBOARD AND FEATURES

Warning Lamps	Color	Indicator	Remarks
Low Fuel indicator	Amber		The lamp comes on when ignition is switched 'ON' and gets 'OFF' after self-check. The symbol lights up continuously if fuel level in the tank is low. Fuel needs to be filled immediately. Note: The tell-tale warning light will start flashing if there is any fault in the fuel system. Contact the nearest TATA MOTORS Authorized Dealer/Service Center immediately.
EPAS (if equipped)	Amber		Illuminates momentarily when ignition is switched 'ON'. Illuminates when there is a fault in the EPAS. Contact a TATA MOTORS Authorised Service Centre immediately.
Daytime running lamps DRL (if equipped)	Green		The lamp comes on when ignition is switched 'ON'. This lamp comes on when the Daytime Running lamp is 'ON'. Note: Parking lamp should be on to start the DRL lamp.
Press Clutch / Brake Pedal to Start Engine (if equipped)	Amber		This lamp comes on with IGN ON till user presses the clutch pedal to start the engine.
Door Ajar lamp	White / Red		All four door and Tail gate are indicated independently when the respective door or tail gate is open.
Key Not Detected (if equipped)	Amber		This lamp comes on when the Valid Smart key is not detected inside the vehicle.

DASHBOARD AND FEATURES

Warning Lamps	Color	Indicator	Remarks
Speed limit warning indicator	Amber		When the vehicle speed crosses 80 kmph, then speed limit warning indicator turns 'ON' along with an audio chime for every two minutes (audible warning). When the vehicle speed is reduced below 75 kmph, then the speed limit warning indicator and the audio warning will turn off.
HHC warning lamp (if equipped)	Amber		Illuminates momentarily when ignition is switched 'ON'. If continuously on then HHC, system is in fault condition. Please take your vehicle to TATA authorized service Centre at the earliest.
Electronic Stability Pro-gram (ESP) (if equipped)	Amber		Illuminates momentarily when ignition is switched 'ON'. If continuously ON then ESP system is at fault condition, Please take your vehicle to nearest TATA authorized service Centre at the earliest.
TPMS	Amber		<ol style="list-style-type: none"> 1. This symbol comes ON and blink for 4 second if Tyre Pressure is LOW/HIGH, Tyre temperature is HIGH, Tyre air pressure leakage. After 4 second symbol will continuously ON till warning is present 2. This symbol comes ON and blink for 20 second if TPMS system has fault and TPMS Sensor fault / missing. After 20 second symbol will continuously ON till fault is present, Please take your vehicle to nearest TATA authorized service center at the earliest.

AUDIO REMINDERS (if equipped)

Key-in Reminder/audio Warning

If you forget the key inside the vehicle when you leave the ignition in 'OFF' position, an audio warning will sound. Remove key to stop the warning.

If No Key Is Detected In The Vehicle

If the vehicle is in ACC ON/IGN ON and the customer takes the smart key out of the vehicle and closes the last door, an audio warning will be sounded for nine times to alert that the key is not in the vehicle.

i NOTE

In this condition customer needs to bring the smart key inside the vehicle.

Parking Lamp 'ON' Reminder

If you forget to turn OFF the park lamp, an audio warning will be started. Switched OFF the park lamps to stop the warning.

i NOTE

Do not forget to turn OFF your park lamp as it may drain the vehicle's battery.

Parking Brake 'on' Reminder

If Park Brake is applied and vehicle is driven, telltale will turn ON and buzzer provides audible warning if vehicle speed is above 5km / hrs continuously.

i NOTE

Disengage the park brake to stop Audible warning.

Reverse Gear Reminder

If reverse gear is engaged, the buzzer sound will alert you for 1 second.

Driver Seat Belt Reminder

If seatbelt is not fastened and vehicle goes above 15 kmph, then final audio warning will go more than 90 seconds. Seat belt tell-tale light will remain continuously ON when audio alarm is active.

Front Passenger Seat Belt Reminder

If front passenger has not fastened seat-belt and if vehicle speed goes above 15 kmph, then final audio warning will go more than 90 seconds. Seat belt tell-tale light will remain continuously ON when audio alarm is active.

i NOTE

Fasten the seatbelt to stop audio warning.

Rear Passenger Seat Belt Reminder

1. The seat belt warning lamp turns on for 60 sec in case seatbelt is not buckled. If speed exceeds 15kmph, audio warning start alarming for 35 sec.
2. When reverse gear is engaged/disengaged, thereafter forward gear selected and speed is below 10 kmph then visual warning turns on and above 10 kmph audio warning start alarming for 35 sec.
3. If rear door accidentally remains unlatched and vehicle speed is below 10 kmph then visual warning turn on, if

DASHBOARD AND FEATURES

speed is above 10 kmph then audio warning start alarming.

i NOTE

Fasten the seatbelt to stop audio warning.

Steering Wheel Locked Chime

If steering wheel is locked in the vehicle, then sound warning will be given to alert user.

AMT Fault Reminder (if Equipped)

If Fault occur in AMT, 3 second audio warning will alert you.

Tyre Pressure Monitoring System

Audible warning for 4 second will be given to alert the user, if

- Tyre Pressure is low
- Tyre Pressure is high
- Tyre temperature is high
- Tyre air pressure leakage

Also Audible warning for 20 second will be given to alert the user, if

- TPMS system has fault

- TPMS Sensor fault or missing.

i NOTE

TPMS is not applicable for spare wheel.

COMBI-SWITCH (RH Stalk) (if equipped)

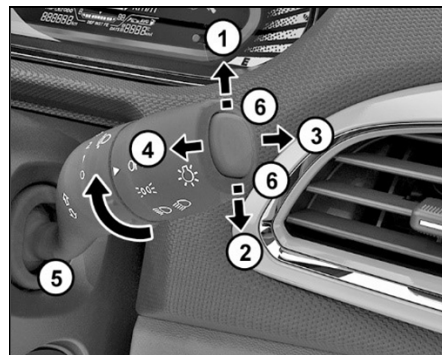

1. Left Turn Signal

Move the lever fully upward.

2. Right Turn Signal

Move the lever fully downward.

i NOTE

When the turn is completed, the signal will cancel and the lever will return to its normal position.

3. High Beam

Move the lever forward to select the high beam function.

Pull the lever back to normal for low beam.

4. High Beam Flash (spring return)

To flash the high beam, pull the lever towards you from the normal position. It will return to its normal position when you release it.

5. Headlamp Rotary Switch

OFF Position

All lamps will remain 'OFF'.



Parking Lamp

Rotate stalk to turn 'ON' the Parking lamps.



Low Beam

Rotate stalk to turn 'ON' the Low Beam function.



Auto Light

The headlights will be automatically switched ON depending on ambient light conditions (while



entering a tunnel or when it is twilight).

6. Lane Change Signal

To signal a lane change, move the lever slightly up or down to the point where the turn signal light begins to flash for six times, but the lever does not latch. The turn signal will flash six times automatically.

7. Head Lamp Leveling Rotary Switch

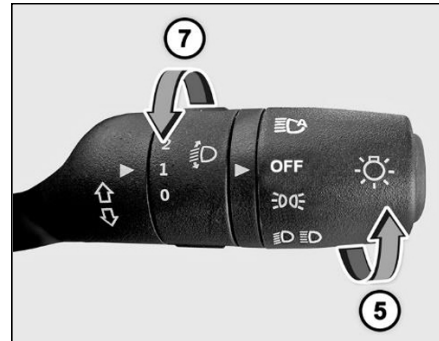

Inner rotary switch on right hand stalk is provided for head lamp leveling. With the inner rotary switch, Head lamp leveling can be done with head lamp in Low Beam

and in 'ON' position. Select correct position before start of trip, when the vehicle is stationary. Depending on the number of passengers and luggage in the vehicle headlamp focus may change. This can be adjusted by rotating the knob to one of the three level positions.

DASHBOARD AND FEATURES

COMBI-SWITCH (LH Stalk) (if equipped)

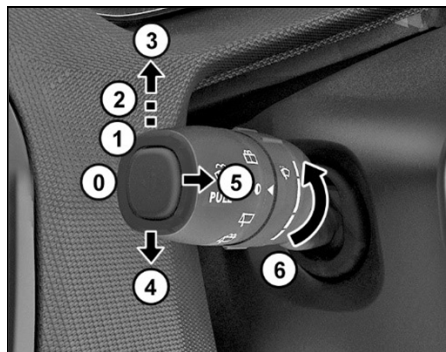

0. 'off' Position

The wiper is switched 'OFF'.

1. Intermittent Wipe

Push the stalk upwards to operate intermittent wipe.



Inner rotary switch on left hand stalk is provided for intermittent front wiper delay. The switch has five delay timers. Push the stalk towards position (1) for single wipe.

2. Slow Wipe

Push the stalk towards position (2) for continuous slow wipe.

3. Fast Wipe

Push the stalk towards position (3) for continuous fast wipe.

4. Flick Wipe (spring return)

Pull the stalk downwards and hold it for continuous wipe, the wiper continuously wipes across the windshield at low speed till the stalk is released.



5 Front Windshield Washer

- Pull the lever little longer, to spray the washer fluid on the windshield.
- The windshield wipers will operate for three cycles after the lever is released and for one more cycle after five seconds.



i NOTE

When you crank the engine, the supply to washer motor is momentarily cut off.

6. Auto Front Wipe (If equipped)

If your vehicle is fitted with rain and light sensor, the wipers will automatically wipe the windscreen, if it senses rainfall. Make sure that the wiper stalk is in Auto position. The wipe sensitivity can be altered with the help of intermittent wipe rotary switch.

DASHBOARD CONTROLS

Fascia switches are provided on the center console above HVAC control panel.

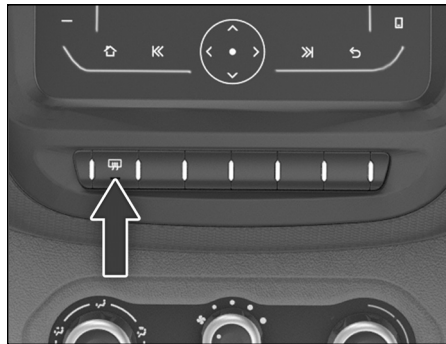

1. Rear Window demister
1. Rear Window Demister

This button turns the rear window demister ON or OFF. The system will be deactivated after 15 min of continuous operation.



STEERING MOUNTED CONTROLS (LHS) (if equipped)

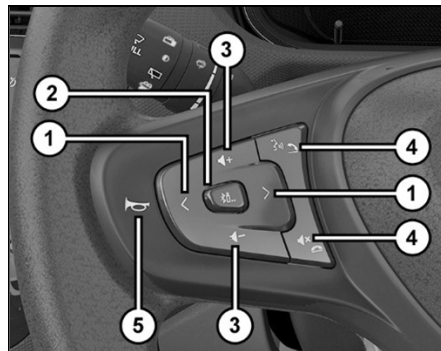

Seek Forward/backward

Press above switch to change radio channels or move between media tracks.



Source

Press above switch to select the required source in the infotainment system i.e. USB, AM, FM and Bluetooth.



Volume

Press above switch to increase or decrease volume of music system / radio.



Mute/phone Reject

Press above switch to reject or hang up a phone call. It is also used to mute the volume of music system/radio.



Receive Calls/ptt (push To Talk)

Press above switch to accept incoming call when a cell phone is connected via Bluetooth.



Voice Recognition

To start, press the voice activation button provided on the steering wheel. The system mutes/ pauses the currently played audio and you will hear a beep sound to indicate the activation of the voice recognition feature. The system displays the Voice Recognition screen on Infotainment to indicate activation of the feature.

Voice Recognition only works when Android Auto, Apple CarPlay is connected

DASHBOARD AND FEATURES

i NOTE

The system will start recognizing your voice command only after the beep. So, speak your command only after you hear the voice activation beep.

Horn Button

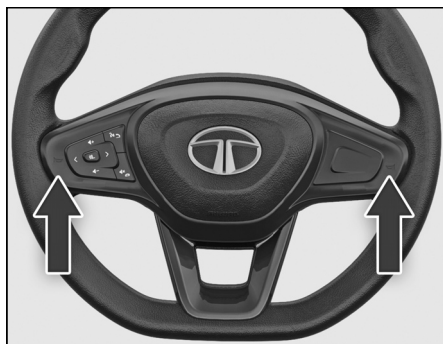

Press to operate the horn.

MIC (if equipped)

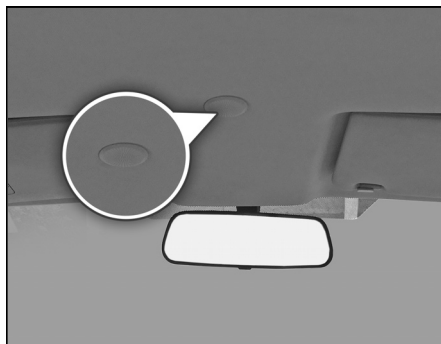

Mic is provided on the roof.

INFOTAINMENT SYSTEM DISPLAY (IF EQUIPPED)

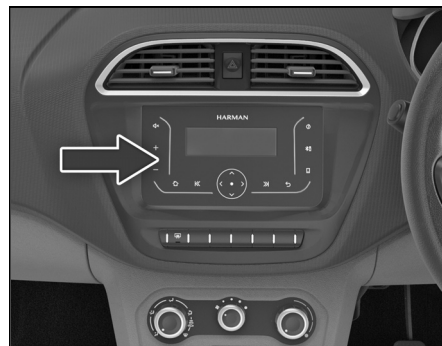

Master / Force Reset Process

If your infotainment system touch screen becomes unresponsive or shows some unusual behavior, then you can restart it to potentially resolve the issue. Follow some basic steps given below and you can restart the system.

To restart the infotainment system

1. Park the vehicle.
2. Hold the Steering wheel Mute button

DASHBOARD AND FEATURES

USB PORT (IF EQUIPPED)

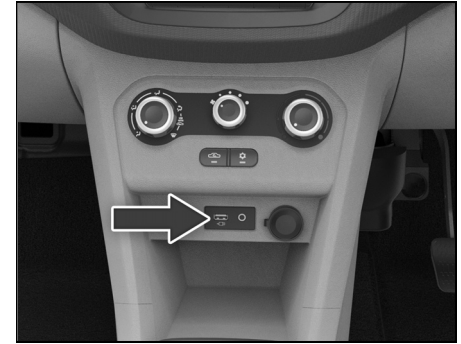

A type USB port is used to connect your portable digital music players, pen drives etc. for playing music tracks through the vehicle's music system.

(long press)  for more than 10 secs and then release the button as soon as the display goes blank.

3. The step above will trigger the infotainment system restart procedure. Wait until the system restarts.
4. When you hold the Steering wheel Mute button  for more than 15 sec, system aborts restart process and display turns ON.

NOTE

- *It is preferable to do one Ignition OFF to ON cycle after Master/Force reset to synchronize vehicle settings with the TATA Infotainment System.*
- *If the reboot does not work or master/force resets are required on a weekly or daily basis, vehicle shall be taken to dealership. There, the dealer can update your firmware or inspect the system for hardware problem.*

- *Force/Master reset keeps the stored data, such as call history, text message information, and previously paired phones as it is.*

DASHBOARD AND FEATURES

POWER SOCKET

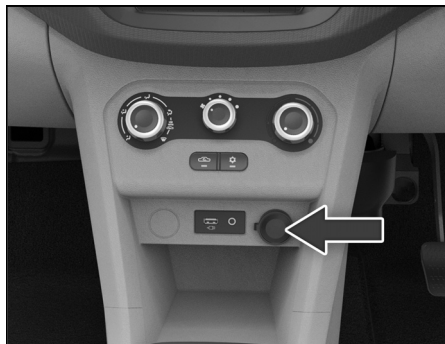

Front Power Socket

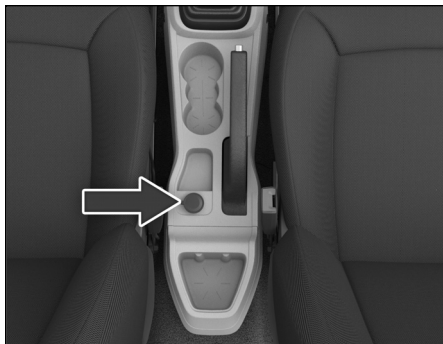

At Center Console

The power socket will work when the ignition switch is in the “ACC” or “ON” position. This socket can be used to provide 12V (10A) power for electrical accessories.

i NOTE

- *Use of unapproved electrical accessories can cause damage to your vehicle’s electrical system.*
- *Make sure that any electrical accessories you use are de-signed to plug into this type of socket and rating.*

ANTENNA

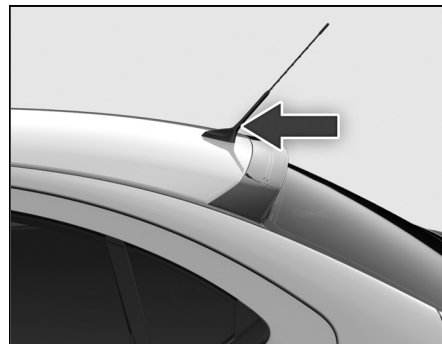

Antenna is located on the roof. Turn the antenna anticlockwise to remove it from the vehicle, if required.

ROOF GRAB HANDLE

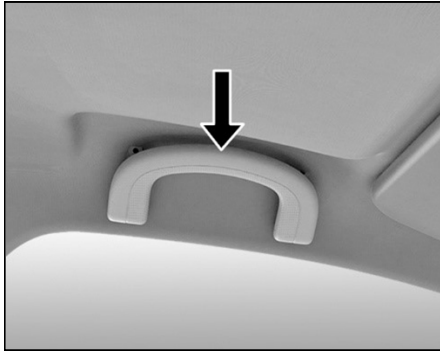

Grab handles are installed on the roof for all seats except for the driver's seat. These help the passengers to position themselves comfortably during the journey.

TAG HOLDER

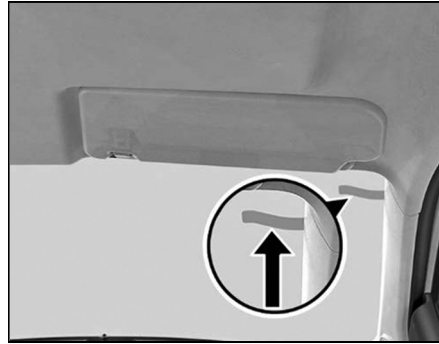

Tag holder is provided near the front windshield for ease of displaying toll, parking tickets, ID's, passes, labels etc.

ROOF LAMP

Interior roof lighting lamp is provided on the roof with inbuilt switch.

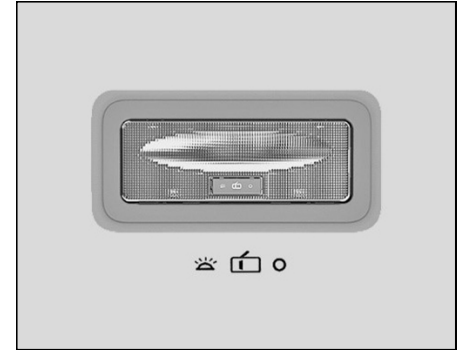

The switch has three positions:

ON - The lamp will turn 'ON' as long as the switch is in this position.



DOOR - In this position the lamp turns to 'ON' when either of the doors are opened. When the last door is closed, the lamp will turn 'OFF' with dimming. This helps settling in the seat and inserting the key in the ignition switch.



DASHBOARD AND FEATURES

When the key is turned to the 'IGN' position, the lamp goes 'OFF' immediately.

OFF - In this position, the lamp will remain 'OFF'.



FRONT LAMP

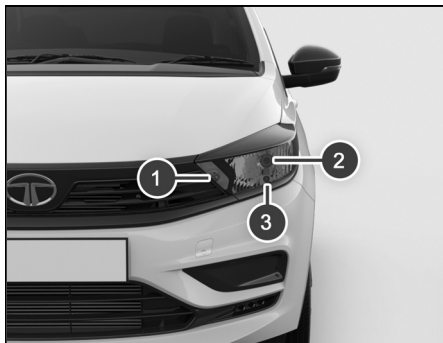

Front lamp consist of:

1. Position /Turn indicator lamp
2. High Beam Lamp
3. Low Beam Lamp

TAIL LAMP

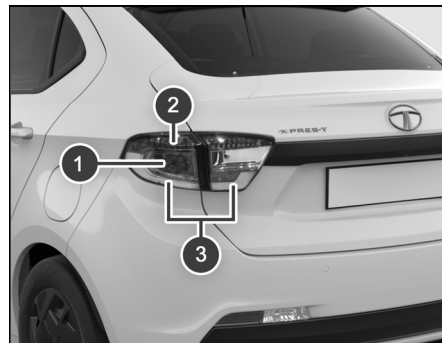

Tail lamp consist of:

1. Turn indicator
2. Stop lamp
3. Parking / Position lamp/ Tail Function

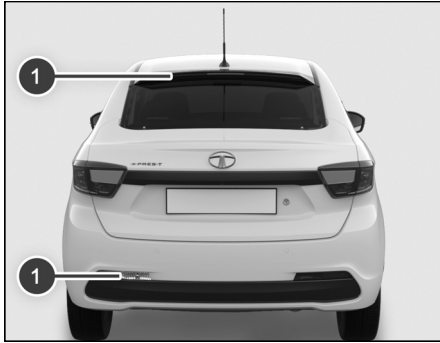

1. HMSL- High Mounted Stop Lamp
2. Reverse lamp (on LH lamp only)

SIDE INDICATOR LAMP

Option I:



Option II:

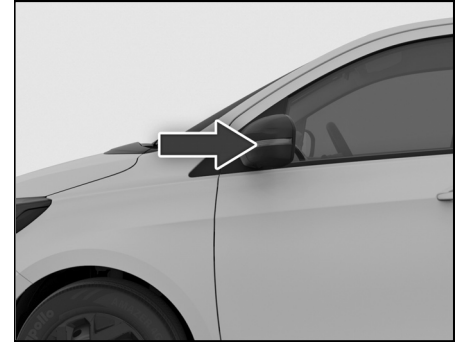

STORAGE COMPARTMENT



- 1. Glove box
- 2. Driver side pocket
- 3. Utility pockets on front doors

- 4. Utility pockets on rear doors
- 5. Center console
- 6. Bottle Holder

- 7. Tailgate compartment

STORAGE AREAS

Glove Box

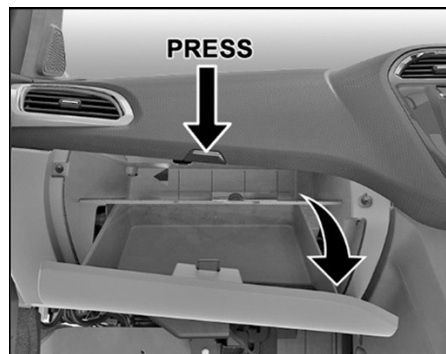

Opening And Closing

To open - Press the knob and open the glove box flap.

To close - Lift glove box flap upward until it engages.

NOTE

Make sure that glove box flap is closed while driving.

Stowage Detail (if equipped)

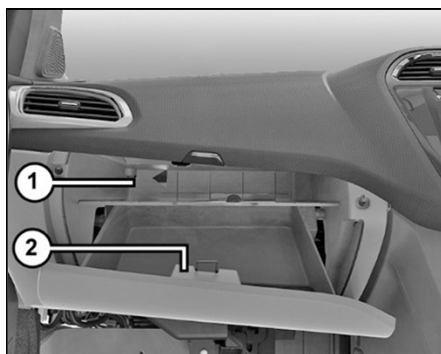

Following items can be stowed in glove box.

1. Laptop holder
2. Pen / Visiting card holder

Driver Side Coin Box

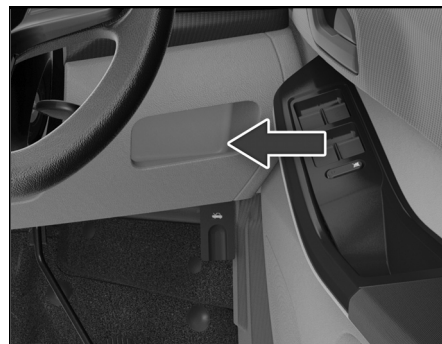

Stowage is provided on RH side of steering wheel for Coin, mobile and wallet.

Utility Pockets On Front Doors

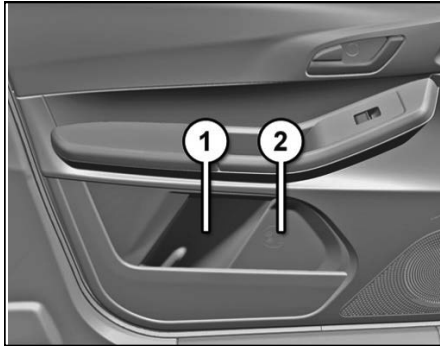

Utility pockets are provided on front doors and it can be used to keep following items.

1. Magazine / paper / books
2. Suitable water bottle

Utility Pockets On Rear Doors

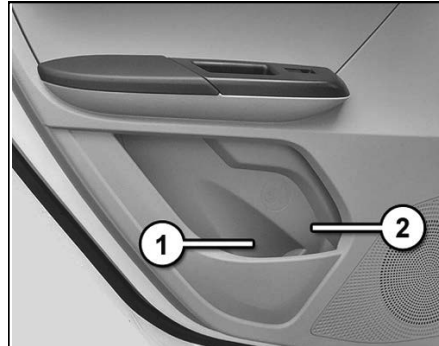

Utility pockets are available on rear doors and it can be used to keep following items.

1. Magazine / paper / books
2. Suitable water bottle

Center Console

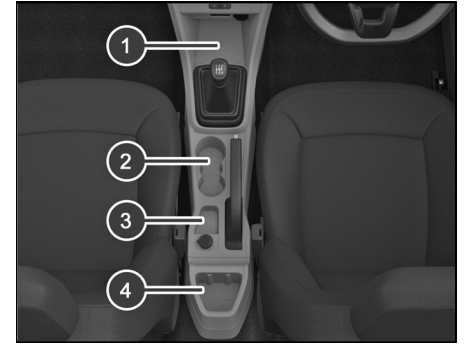

1) Stowage compartment

Stowage compartment provided for keeping cell phones, iPod's, chargers etc.

2) Cup holder

3) Coin storage

4) Bottle holder

STOWAGE AREAS

Tailgate Compartment (luggage)

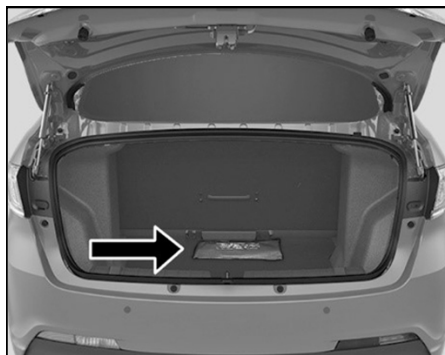

Store the luggage in tailgate compartment. You can keep suitcase, bags, etc.

WARNING

- Distribute the items of luggage as evenly as possible.
- Position heavy loads towards rear seat and low down in the trunk as possible.
- Do not allow occupants to travel in the luggage compartment.

- Do not place anything on luggage cover as it could obstruct driver's rear view. Also in case of an accident or sudden braking, it could cause an injury to occupants.

Card Holder (If equipped)

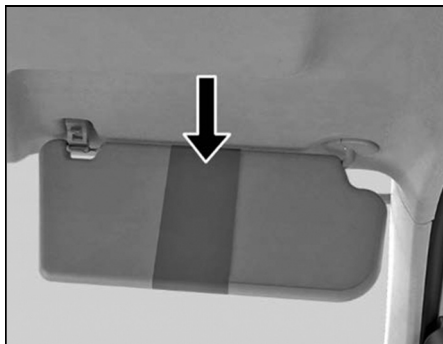

A pocket is provided on the back of the driver side sun visor to keep cards, papers etc.

HOOKS (If equipped)

Collapsible Hook

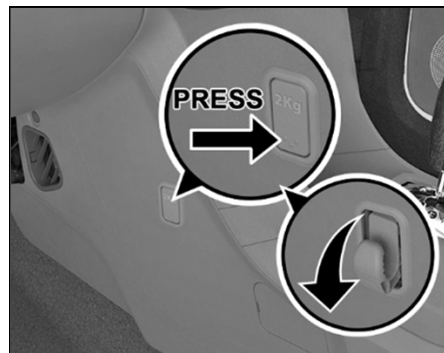

Collapsible hook is provided for hanging small carry bags etc.

AIR DISTRIBUTION

The air is distributed through the vents in the passenger compartment as shown below:

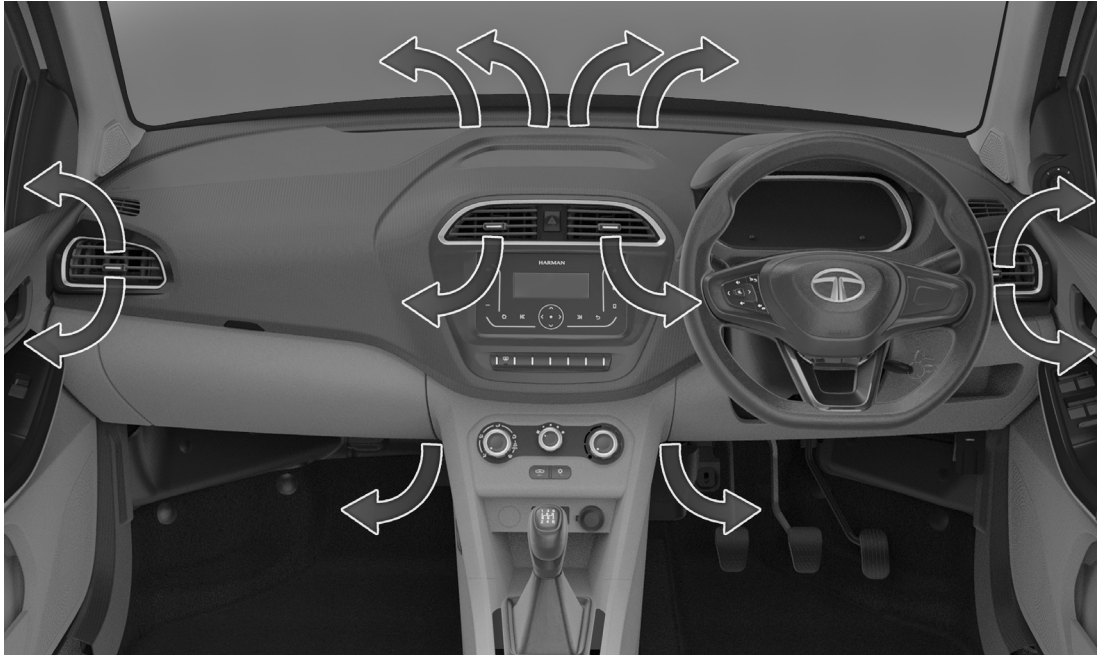

Note- Above image is only for reference.

CLIMATE CONTROL

AIR VENTS

Air vents are available on the dashboard. The direction of air flow can be adjusted using sliders on the respective vents.

Centre Air Vents (Front)



Side Air Vents (Front)

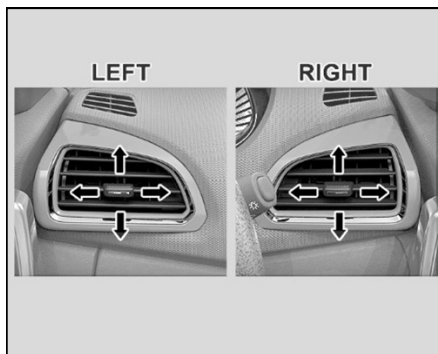

PRE DRIVING CHECKS

Make Sure That

- Windshield, windows, mirrors, lights, and reflectors are clean and unobstructed.
- Tool kit, jack & handle, warning triangle, owner's manual, first aid kit and vehicle documents are available and stored at their locations.

WARNING

Do not put any mat on the floor car-pet near control pedals area from occupant safety point of view. If floor mats are used by end user, for different reasons, they need to be secured in place with the provided floor carpet clips. This is recommended, as in normal driving conditions, floor mats may slip forward and interfere with pedals.

- All doors, engine bonnet and tail gate are securely closed and latched.
- All occupants should always wear seat belts or suitable CRS as applicable while travelling.

- Objects, luggage or loads are secured correctly against slipping or tipping.
- Rear seat is securely latched.
- There is sufficient fuel for the trip.

Daily Check

- Tyres for unusual wear, cracks or damage and embedded foreign material such as nails, stones, etc.
- Traces of fluid and oil below vehicle.

NOTE

Water dripping below the car is normal. This is due to the usage of air conditioning system.

- All lamps, wipers, wiper blades and horn for proper operation.
- All switches, gauges and tell tales are working properly.

Adjust

- Seats, head restraints and steering wheel position.
- Adjust all the mirrors before you start the car.

Weekly Check

- Engine oil level
- Coolant level
- Brake fluid level
- Windshield washer fluid level
- Battery electrolyte level
- Fuel level

NOTE

Tyre pressure should always be measured in cold conditions. Do a check of the tyre pressure and condition after every 15 days, including the spare tyre.

STARTING AND DRIVING

DRIVING TIPS

Fuel consumption, engine, transmission, brake and tyre wear are mainly affected by the below factors:

- Operating conditions of your vehicle
- Your personal driving style

Operating Conditions

- Avoid frequent starts and stops as these actions increase the fuel consumption of the vehicle.
- Always ensure correct tyre pressure.
- Do not carry any unnecessary weight.
- Regularly service your vehicle and adhere to the recommended service maintenance schedule.

Personal Driving Style

- Do not press the accelerator pedal when starting the engine.
- Do not warm up the engine when the vehicle is stationary.
- Always adapt your driving style to suit the prevailing road, weather conditions, and maintain a safe distance from the vehicle in front. Drive care-

fully.

- Avoid frequent, sudden acceleration and braking
- Select appropriate gear according to varying speeds and load conditions.

NOTE

- *Do not rest your foot on the clutch pedal while driving.*
- *If clutch pedal is pressed for more than 3 minutes, then release the clutch pedal & again press clutch pedal with start stop button to crank the engine.*
- Switch 'OFF' the engine in stationary traffic or at signals.
- Keep an eye on the vehicle's fuel consumption.
- Safety systems are merely aids designed to assist driving. You are responsible for the distance between the vehicles in front, for vehicle speed and anticipating braking in good time.

WARNING

- You could lose control of your vehicle if you try to adjust the driver's seat, head restraint, mirror, steering wheel and fasten the seat belt while driving. There is a risk of an accident.
- Do not rest your hand on the shift lever during driving; Pressure transmitted from your hand may result in premature wear of the transaxle internal gear shift mechanism.
- Press the clutch fully while shifting the gears. The reverse gear should be engaged only when the vehicle is stationary. Transmission may get damage by trying to shift into reverse gear while the vehicle is moving. Wait for 5 seconds after declutching to ensure smooth engagement of the reverse gear or shift into one of the forward gears for a moment while clutch is pressed fully. This will avoid grinding of reverse gear while shifting.

Good Driving Practices

- Slow down before you shift to a lower gear. This helps the engine to keep a lower rpm and result in less wear and tear of the engine components.
- Avoid frequent brake application which can cause overheating of brakes.
- Slow down the vehicle when you drive in cross winds to get better control over the vehicle.
- Avoid high speed when cornering or turning.
- Press the clutch fully while shifting gears.
- Make sure that vehicle is completely stationary before you attempt to shift in reverse gear.
- Drive slowly on wet roads.
- You can get extra braking from the engine by shifting to a lower gear. This can help you to maintain a safe speed and prevent your brakes from overheating specially while going down a hill.

Driving Through Flooded Water

Water may enter the vehicle interior and engine compartment which could damage engine, electronic & electrical systems. Judge the depth of water before driving through it.

If at all the situation demands that you have to drive through water then;

- Keep engine in higher RPM and crawl the vehicle in low gear.
- Flowing or rushing water creates strong forces. Driving through flowing water could cause the vehicle to about trying to drive through flowing water.
- Lightly apply the brake pedal to dry the liners until the brakes work normally once you are out of water.

WARNING

Do not attempt to start the engine if vehicle gets flooded due to water. Tow the vehicle to a safe place. Contact a nearest TATA MOTORS Authorised Service Centre.

Driving On Wet Roads

- Check wiper blades, lights and brakes for proper functioning.
- Check the tyre condition visually, tyre treads depth, cut mark, worn out etc.
- Avoid harsh braking and sharp turns. It may cause loss of control and lead to a skid.
- For slowing down, shift to lower gears and brake gently.
- Keep lights 'ON' if visibility is poor.

WARNING

On wet road or during light showers, "Aquaplaning" can occur. "Aquaplaning" is the loss of direct contact between the road surface and the vehicle's tyres due to a water film forming between them. Steering or braking the vehicle can be very difficult, and loss of control can occur.

There is no hard and fast rule about aquaplaning. The best advice is to slow down when the road is wet.

STARTING AND DRIVING

NOTE

If you have driven for a long time in heavy rain without braking, there may be a delayed reaction from the brakes when braking for the first time. You have to press the brake pedal more firmly. Maintain a greater distance from the vehicle in front

Driving on Snow Roads

While driving on snow, it is advisable to use the snow chain on roads. Follow assembly and safety instruction provided by the snow chain manufacturers.

WARNING

Wet ice (0°C and freezing rain), snow or ice can be slick and very hard to drive on. The vehicle will have much less traction or “grip” under these conditions. Try to avoid driving on wet ice. Whatever the conditions, drive with caution. Accelerate and slow down with care. If accelerating too fast, the drive wheels will lose even more traction.

Allow more stopping distance under these conditions. Braking should be started sooner than on dry pavement. Allow greater following distances on slippery roads.

Night Driving

- Ensure that all lights are working and windshield, window glasses are clean.
- Drive more slowly at night than in the daytime, as the visual range is restricted at night. Maintain a speed such that you can stop within illuminated distance of headlamps.
- Do not use the high beam unless inevitable. It may dazzle the driver of the oncoming vehicle, thus causing an accident.
- Use headlamp main/dip beam to alert other road users on turns/ cross roads etc.
- Use side indicators for lane change or turning

Gradient Driving

When climbing gradient, the vehicle may

begin to slow down and show a lack of power. If this happens, shift to a lower gear and apply power smoothly so that there is no loss of traction.

When driving down a hill, the engine braking should be used by shifting into a lower gear. Do not drive in neutral gear or switch off the engine.

Depending on the severity of the gradient, shift into appropriate gear. Use engine braking judiciously without over- revving the engine. Brake application under such situations should be done very.

WARNING

When descending on sharp gradients, NEVER turn the ignition key to the ‘OFF’ position. Emission control system damage may result.

Highway Driving

Stopping distance progressively, increases with vehicle speed. Maintain a sufficient distance between your vehicle and the vehicle ahead.

For long distance driving, perform safety

checks before starting a trip and take rest at certain intervals to prevent fatigue.

Recommended Fuel Economy Speeds (For MT)

Gear	Petrol
	Speed(kmph)
1	15
2	30
3	45
4	65
5	80

Tips For Obtaining Better Fuel Efficiency

- Always maintain the specified tyre pressure during fuel top-ups and also before a long trip. Vehicle running with low tyre pressure will consume more fuel than the one running with specified tyre pressure.
- Keep the vehicle clean. Get rid of the unwanted stuff lying in the boot etc., to reduce weight.
- Regularly inspect your vehicle for any

leakages, worn out wires by rat bites etc.

- Always follow periodic & regular service schedule of the vehicle.
- In places with high dust content (e.g.: Gurgaon, Jaisalmer etc.), Clean the air filter element at every 5000 km.
- Anticipate the road conditions and drive in a smooth manner.
- Do not accelerate excessively when you are in lower gears (1st or 2nd). Be gentle on the accelerator when you are in traffic. In lower gears, opening up the throttle will increase the engine rpm while keeping the vehicle at lower speeds. This reduces the fuel efficiency of the vehicle.
- Be in the maximum possible higher gear at a given speed. This reduces the engine operating speeds which means the engine is running at lower rpm (Revolutions per Minute) for the same vehicle speed. Lesser the number of engine revolution lesser the fuel burned.
- Avoid harsh braking.

- Maintain healthy driving habits & while decelerating, do coasting in gear and not in neutral or with clutch pedal pressed.
- Use the car AC only when you require. For cooling, keep the blower speeds low, as at higher blower speeds, the AC consumes more electric power which is ultimately drawn from engine by burning fuel.
- Avoid unnecessary extra electrical loading on the car.
- Stop the engine wisely at traffic signals. Switch 'OFF' the engine at the traffic signal only if the stoppage time is high (typically more than 30 sec).
- When you drive on highways, close all the windows. This reduces the drag on the vehicle and improves fuel efficiency.
- Do not over speed. Follow the speed limits. With increasing speed, the engine rpm increases to overcome external air resistance and this reduces fuel efficiency.

STARTING AND DRIVING

Running-in Period (For MT)

The purpose of running in a car is to give time for the mechanical parts to settle so that they work efficiently. This involves gentle acceleration and not revving the engine too much. This is done by changing gears early for the first 1,500 – 1,800 km. This will increase the life of the engine.

The more you look after the engine when it is new, the more satisfied you will be with its performance in the future.

Do not exceed the following road speeds during running in period.

Gear	Petrol
	Speed(kmph)
1	20
2	40
3	60
4	80
5	100

Avoid heavy loads, e.g. driving at full throttle, during this period. Change gears judiciously.

i NOTE

Avoid excessive revving up of engine rpm. Do not keep engine at idling for long duration.

SEAT ADJUSTMENTS

Front Seat Adjustments

Following seat adjustments can be carried out manually.



1. Seat height adjustment lever (if available)
2. Backrest recliner adjustment lever
3. Seat forward / rearward adjustment lever

⚠ WARNING

Do not adjust the driver's seat while driving. Adjusting the seat while driving could cause the driver to lose control of the vehicle.

Seat Height Adjustment (if equipped)

To raise the seat, pull and continue pumping the lever (2) in the upward direction until the seat is at the desired height.

To lower the seat, pump the lever downward until the seat is at desired height.

i NOTE

Adjust the seat backrest until your arms are slightly angled when holding the steering wheel.

⚠ WARNING

Do not travel in a moving vehicle with the seat backrest in an excessively reclined position as this can be dangerous.

Seat Backrest Angle Adjustment

To change the seat back rest angle, lean forward slightly and pull up the lever (1). Adjust seat backrest until it reaches desired comfortable position. Make sure that lever returns to its original position and seat is securely latched.

Seat Forward / Rearward Adjustment

Lift lever (3) and slide the seat forwards or to the rear. Release lever and make sure that seat is securely latched.

i NOTE

Adjust the driver seat position in such a way that the driver will be able to operate the control pedals comfortably.

Occupant Detection Sensor

An occupant detection sensor is installed in the front passenger seat to detect whether the seat is occupied or not. The sole purpose of this sensor is to issue seat belt reminder warnings for the front passenger seat. The sensor does not have any control on the deployment of airbags.

⚠ WARNING

Any modification in the seat material or addition of seat cover may damage or affect the performance of the sensor.

Rear Seats



STARTING AND DRIVING

REAR VIEW MIRRORS

Inside Rear View Mirror (IRVM)

To adjust the mirror move the mirror up, down or sideways manually to obtain the best rear view.

When you drive at night, set the selector tab to select anti-glare mode (if equipped) to reduce glare from the headlights of vehicles behind you.

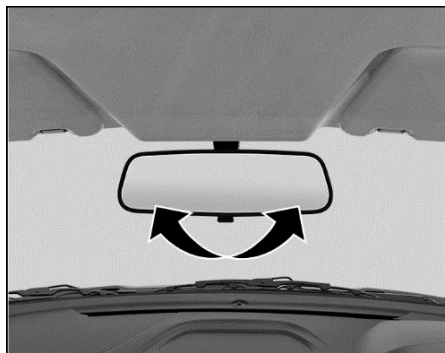

i NOTE

Use antiglare position only when necessary, as it reduces rear view clarity.

Outer Rear View Mirrors (ORVM)

You can adjust the outer rear view mirrors manually by Tip-Tap (By hand) or remotely by knob. Adjust the outside rear view mirrors to desired position.

i NOTE

Objects visible in mirror are actually closer than they appear. Always make sure of the actual distance from the road users traveling behind by glancing over your shoulder.

Manual ORVM Adjustment (if equipped)

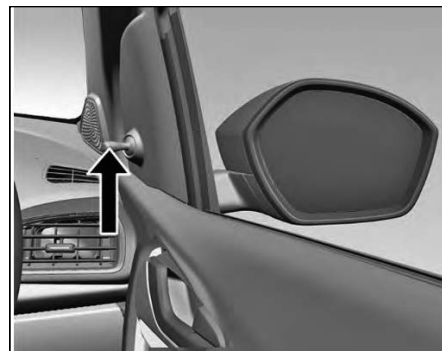

You can adjust the outer rear view mirrors manually.

Manual Folding

ORVMs can be folded or unfolded manually. This is applicable only for vehicles which are not equipped with motorized folding provision.

Motorized ORVM Adjustment & Auto Fold (if equipped)

The switch to adjust the motorized mirrors is located on the driver's door. You can ad-

just the mirrors when the ignition switch is in the “ACC” or “ON” position.

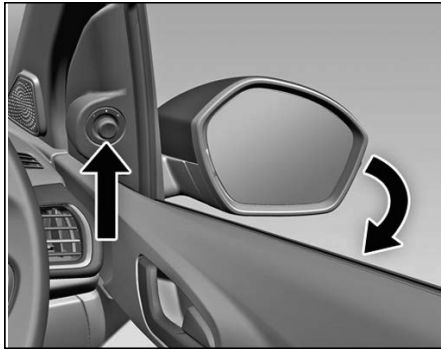

To Adjust The Mirrors

- Move the mirror selection switch to L (for left side) and R (for right side) to select the mirror you wish to adjust.
- Use the four positions of the knob to adjust the rear view mirrors to required position.

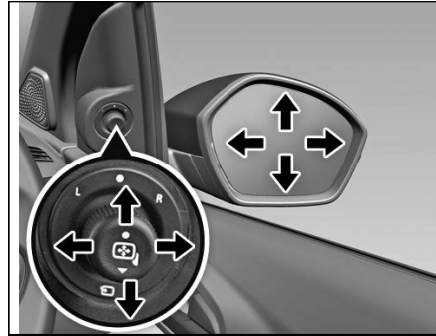

i NOTE

When vehicle is locked, mirrors will be folded automatically. When it is unlocked, mirrors will be unfolded automatically.

Option 2: Auto Folding By Knob

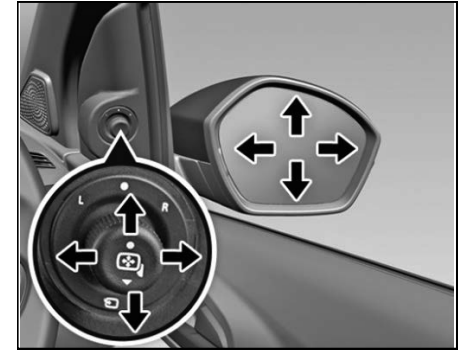

To fold / unfold the ORVMs, keep the Selector switch in center position (i.e. neither 'L' nor 'R', position) and then toggle down. This will operate when the ignition switch is in the “ACC” or “ON” position.

STARTING AND DRIVING

SUN VISORS (if equipped)

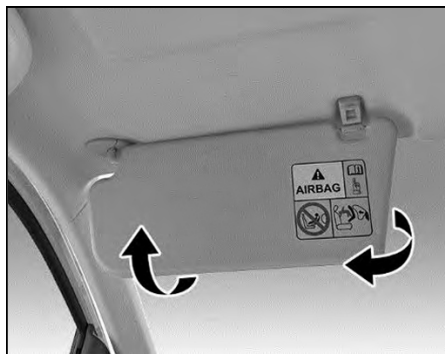

The sun visors can be pulled down to block the glare coming through the windshield.

To block the glare from side windows, pull down the sun visor and release it from retainer. Swing the sun visor to the side.

Vanity Mirror (if equipped)

Vanity mirror is provided on the back of the front passenger / Driver side sun visor.

ELECTRIC POWER ASSISTED STEERING (EPAS)

Your vehicle is equipped with electric power assisted steering system. The EPAS system makes steering the vehicle easier with less effort.

In EPAS system, the steering effort becomes heavier as the vehicle speed increases and becomes lighter as the vehicle speed decreases for better control of the vehicle at different vehicle speeds.

If the engine is 'OFF' or if the EPAS system becomes inoperative, the vehicle still can be steered with more steering effort.

This EPAS system is available with the following assist features.

i NOTE

- *A click noise may be heard from the EPAS relay after the ignition switch is turned ON or OFF position.*
- *The steering wheel may not unlock normally in some cases when ignition key turned 'ON'. If this happens, turn the steering wheel to the right*

or left slightly to unlock the steering wheel while turning the ignition key.

⚠ WARNING

Below are the symptoms of the system malfunction. Then, take your vehicle to the nearest TATA MOTORS service center and have the EPAS system checked as soon as possible.

- The EPAS warning light does not illuminate even in case of abnormal operation.
- If the EPAS system does not operate normally, the warning light  will illuminate on the instrument cluster. The steering wheel rotation may become difficult to control or operate.

i NOTE

- *The steering effort can suddenly increase, if the operation of the EPAS system is stopped to prevent serious accidents when it detects mal*

function of the EPAS system during self-diagnosis.

- When steering for a prolonged period, the steering effort will increase to prevent overheating and damage to the steering system.

STEERING WHEEL ADJUSTMENT



You can adjust the steering wheel position to suit your convenience.

The release lever is located under the steering column.

To Adjust The Steering Wheel

- Adjust the seat to a comfortable position.
- Push “Tilt lever” completely down to unlock the steering column.
- Adjust the steering wheel to the desired position.

- Pull release lever up completely to lock the steering column.
- Make sure that steering wheel is securely locked by checking up and down direction.

NOTE

When adjusting the steering wheel, make sure that:

- *You can operate control pedals without any obstacles.*
- *You can see all the displays in the instrument cluster clearly.*

WARNING

Before you start the car, make sure the steering wheel position is locked. Do not unlock or adjust the steering wheel while the vehicle is in motion.

STARTING AND DRIVING

WARNING

You could lose control of your vehicle if you try to adjust the steering wheel while driving. There is a risk of an accident.

STEERING LOCK AND IGNITION SWITCH (If equipped)

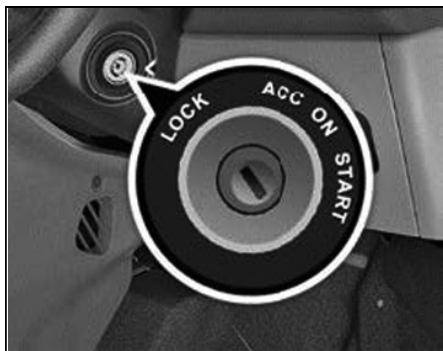

The ignition switch has the following four positions:

LOCK - This is the normal parking position. Key from lock can be removed in this position only.

“LOCK” position prevents normal use of the steering wheel after the key is removed.

To release the steering lock, put the key in the slot and turn it clockwise to one click (ACC).

ACC - Accessories such as the infotainment system can be operated, but the engine remains ‘OFF’. Steering gets unlocked.

ON - This is the normal operating position. All electrical systems are ‘ON’.

START - Turn the key further clockwise to the START position, (spring loaded) to start the engine. As soon as the engine starts, release the ignition key, which returns to ON position. While cranking, all accessories will be momentarily ‘OFF’.

Illuminated Key Ring (if equipped)

When the vehicle is unlocked, the illuminated key ring glows. This helps to locate ignition switch in the dark.

STARTING AND STOPPING (with-out PEPS)

Starting The Engine

Make sure that parking brake is engaged and vehicle is in neutral gear.

Press the clutch pedal fully and crank the engine. Do not press the accelerator pedal when starting the engine.

NOTE

The Starter protection system fitted in this vehicle does not allow you to crank

the engine until you fully press  the clutch pedal.

Release the key as soon as the engine starts. Repeat if engine does not start.

NOTE

- *The Starter protection system switches off the starter when it is continuously cranked for more than 10 secs. In such a case, get the key back to 'OFF' position & wait for 30*

secs.

- *For vehicle equipped with turbocharger, after you start the engine, run the engine at idle speed for 30 seconds. Do not press accelerator pedal while starting the engine to avoid damage to the turbocharger.*

Starting Off

To start off, press the clutch pedal fully and shift into 1st gear.

After releasing the parking brake, gradually release the clutch and slowly press the accelerator.

NOTE

When shifting or starting off, do not race the engine. Racing the engine can shorten engine life and affect smooth shifting.

Stopping The Vehicle

For vehicle equipped with turbocharger, turn the key to 'ACC' position to switch off

the engine. Before switching off the engine, run the engine at idle speed for 30 seconds and then switch off. This will allow the engine oil to lubricate the turbocharger, till its speed is fully reduced and also allow the unit to cool down.

WARNING

- Do not switch off the ignition while driving.
- For vehicle equipped with turbocharger, do not switch the engine off when it is running at high speed. This will lead to premature turbocharger bearing wear.
- If you switch off the ignition while driving, safety-relevant functions are only available with limitations, or not at all. This could affect the power steering and the brake boosting effect. You will require considerably more effort to steer and brake. There is a risk of an accident.

STARTING AND DRIVING

ENGINE PASSIVE START - CONDITIONS

Single Press Start

- Bring the smart key with you and sit in the driver seat.
- Press the clutch pedal and then press the start/stop switch.
- Green colour LED on start/stop button will turn ON.
- Once engine is started successfully, the green colour LED on start/stop button stays ON.

Two Step Start

Step 1

- Have the smart key with you and sit on the driver's seat.
- Press the start/stop button without pressing clutch pedal.
- Amber colour LED on start/stop switch turns ON.
- Engine will remain OFF and all electrical equipment and infotainment system can be used. Steering is unlocked.

Step 2

- Press the clutch pedal and then press start/stop button to start the engine.
- Green colour LED on start/stop button will turn ON.
- Once engine start successfully, green colour LED on start/stop switch will remain ON.

Three Step Start

Step 1

- Have the smart key with you and sit on the driver's seat.
- Press the start/stop button without pressing clutch pedal.
- Amber colour LED on start/stop button will turn ON.
- Limited information will be displayed on instrument cluster and steering will be unlocked. Engine remains OFF.

Step 2

- Press the start/stop button without pressing clutch pedal again.
- Green colour LED on start/stop button will turn ON.

- Engine will remain OFF but all electrical equipment and infotainment system can be used.

Step 3

- Press the clutch pedal and then press start/stop button to start the engine.
- Green colour LED on start/stop button will turn ON.
- Once the engine is started successfully, the green colour LED on start/stop button stays ON.

GEAR SHIFTING

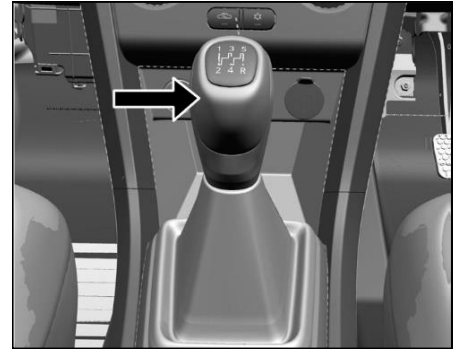

The gearshift pattern is as shown on the gear lever knob. Gear shifting should always be done with the clutch pedal fully pressed.

i NOTE

- Gear recommendation is displayed when the clutch pedal is fully released.
- If "F" is displayed in DIS of instrument cluster, it means 'Fault' condition. Contact TATA MOTORS

ENGINE PASSIVE STOP - CONDITIONS

Single Press Stop

- IGN is ON and engine is running.
- Press the start/stop button with or without clutch.
- ACC and IGN turns OFF.
- LED on start/stop switch turns OFF.

Single Long Press Stop

- IGN is ON and engine is running.
- Vehicle is in running condition i.e. wheel rpm >10 RPM or wheel sensor faulty.
- Press the start/stop button for more than three seconds.
- IGN returns OFF, ACC remains ON.
- Amber colour LED on start/stop switch turns ON.

⚠ WARNING

When vehicle is in OFF mode (ACC, IGN and Crank OFF) and user tries to lock the vehicle from outside by press

ing any door handle switch and if PEPS detects that the smart key is left inside the vehicle, an audio warning/ chime is sounded.

i NOTE

If clutch pedal is pressed for more than 3 minutes, then release the clutch pedal & again press clutch pedal with start stop button to crank the engine.

STARTING AND DRIVING

Authorized Dealer/Service Center.

- *Press the clutch fully when gear shifting. The reverse gear should be engaged only when the vehicle is stationary.*
- *Use the clutch only to shift gears and do not use it when vehicle is stationary on a slope, as the car will roll down due to gravity.*
- *If all doors are closed when the vehicle is in ACC/IGN/RUN mode and if PEPS does not detect the smart key inside the car, then an audio warning is given.*
- *Do not rest your hand on the shift lever during driving; Pressure transmitted from your hand may result in premature wear of the transaxle internal gear shift mechanism.*

Current Gear Indication

The Driver Information display (DIS) in the Instrument Cluster indicates the current gear position engaged.



Gear Recommendation



Up or down arrow will be displayed in DIS, recommending whenever gear should be shifted to up or down.

REVERSE GEAR

To engage reverse gear, shift to reverse position as shown on the gear lever knob.

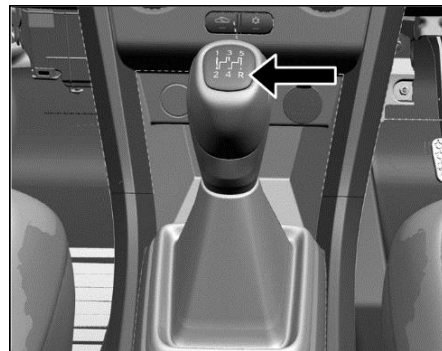

i NOTE

Press the clutch fully when gear shifting. The reverse gear should be engaged only when the vehicle is stationary.

DRIVING

Climbing Sharp Gradients On Loose Surfaces (MT)

Start off smoothly in a suitable gear. Accelerate smoothly so that there is no loss of traction by over-revving of the engine.

Choose a smooth slope and select the appropriate gear so that gear changing in the middle of the climb is not required.

Changing gears in the middle of the climb can cause loss of momentum and engine stalling. Shifting to lower gear has to be done cautiously to avoid loss of traction.

Under no conditions should the vehicle be moved diagonally across a hill. The danger is in loss of traction and sideways slippage, possibly resulting in toppling over. If unavoidable, choose a mild angle and keep the vehicle moving.

If the tyres start to slip within few feet at the end of the climb, keep the vehicle stable by steering left and right. It gives increased grip to the tyres.

If the vehicle stalls or loses headway while climbing a steep hill, make a quick

shift to reverse and allow the vehicle to move back with the help of engine braking.

Descending Sharp Gradients (MT)

Depending on the severity of the gradient, shift into appropriate gear. Use engine braking judiciously without over-revving the engine.

Brake gently in such situations.

WARNING

When descending on sharp gradients, do not turn the ignition key to the 'OFF' position. The braking assist and steering assist may malfunction and the emission control system may be damaged.

STARTING THE ENGINE

Make sure that parking brake is engaged and vehicle is in neutral gear.

Press the clutch pedal fully and crank the engine. Do not press the accelerator pedal when starting the engine.

Press the clutch pedal fully and crank the engine. Do not press the accelerator pedal when starting the engine.

Release the key as soon as the engine starts. Repeat if engine does not start.

WARNING

The engine emits poisonous exhaust gases such as carbon monoxide. Inhaling these exhaust gases leads to poisoning. There is a risk of serious health problems. Therefore, never leave the engine running in enclosed spaces without sufficient ventilation.

STARTING AND DRIVING

NOTE

After starting, run the engine in idle speed for at least 30 seconds. Do not press accelerator pedal while starting the engine to avoid damage to turbocharger.

BRAKING

Your vehicle has vacuum assisted brakes.

The distance needed to bring the vehicle to a halt increases with the speed of the vehicle. Start applying brake anticipating the distance and slow down gradually.

WARNING

- Do not use the brake pedal as a footrest.
- If you rest your foot on the brake pedal while driving, the braking system can overheat and cause fading of brake pads. This increases the stopping distance and can even cause the braking system to fail. There is a risk of an accident.
- Do not press the brake pedal and the accelerator pedal at the same time.

If you have driven for a long time in heavy rain without braking, there may be a delayed reaction from the brakes when you brake for the first time. This may also occur after the vehicle has been washed.

Brake performance may become poor and unpredictable if brakes are wet.

After you drive through water or if you wash the underside of the vehicle, test the brakes at slow speeds to see if the brakes work fine. If the brakes are less effective than normal, dry them by repeatedly applying the brakes at slow speeds until the brakes have regained their normal effectiveness.

Check traffic conditions before doing the above activity.

Braking On Downhill Gradients

When you drive on downhill slopes, reduce the load on the brakes by shifting to a lower gear. This is called as engine braking and aids to reduce overheating and wear of brakes.

WARNING

- Do not shift to lower gears on a slippery road surface to increase the engine's braking effect. By doing so, the tyres could lose their grip.
- There is an increased danger of skidding and accidents.

CREEPING FEATURE

Creeping function allows the car movement without accelerator Pedal pressed when the brake pedal is released.

This functionality is generally used in parking maneuvers, with 1st or 'R' gear engaged, in this situations the driver enters and exits from creeping just by pressing the Acc. pedal.

- Creep feature is enabled for Manual as well as Auto Mode for first and reverse gear.
- After vehicle cranking and brake pedal released vehicle starts moving without pressing accelerator Pedal.
- Whenever accelerator pedal is pressed creep function will be disabled.
- Whenever driver door is opened and / or parking brake is engaged, creep function will be disabled.

Kick Down Feature (if Equipped)

In Automatic mode, while driving at a constant speed if the accelerator pedal is quickly pressed the AMT downshifts the gear (if required). It ensures optimum acceleration to complete overtaking in minimal time.

STARTING AND DRIVING

PARKING BRAKE

Mechanical parking brake acting on the rear wheels is provided on the vehicle.

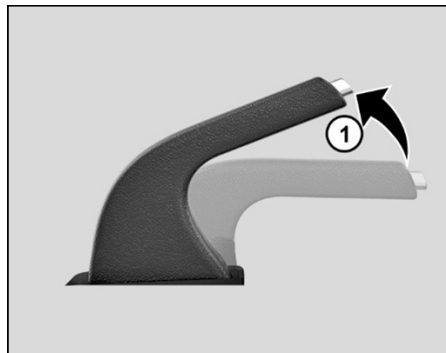

Parking brake applied

To apply the parking brake, pull the lever up fully (1). The parking brakes tell-tale light comes on in the instrument cluster.

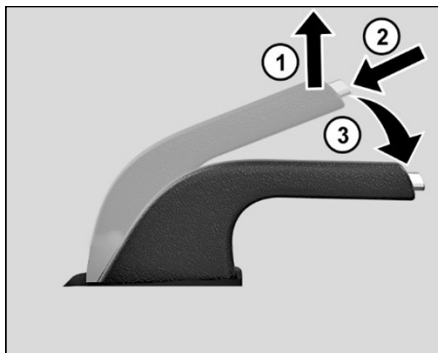

Parking brake released

To release it, pull the lever up slightly (1), press the release button (2) and push the lever down (3). The parking brakes' telltale in the instrument cluster will turn 'OFF' when the lever is fully released.

i NOTE

Apply the parking brake properly before leaving the vehicle and release it before moving.

VEHICLE PARKING

- Park the vehicle in a safe place. Switch on the indicator signal before turning to park.
- Apply the parking brake.
- Make sure that all window glasses are closed and all lamps are turned 'OFF'.
- At night, put on the parking lights if required.
- Remove the key from the ignition switch and lock the vehicle.
- Use wheel chocks if the vehicle is parked on a slope.

i NOTE

When parking on a downhill gradient, place the gear lever in 'Reverse' position. While parking on uphill gradient, place the gear lever in the '1st' position.

⚠ WARNING

Never leave children unsupervised in the parked vehicle. They could also operate the vehicle's equipment. There is

a risk of an accident and injury.

i NOTE

Do not use parking brake for braking unless unavoidable circumstances like when service brake is not working properly. The braking distance is considerably longer and the wheels could lock. There is an increased danger of skidding and accidents.

EMERGENCY EQUIPMENT

You should be familiar with the location of the emergency equipment provided in the vehicle and how to use it.

Do a check of this equipment periodically and make sure that they are in proper working condition and stowed at their locations.

First Aid Kit

The first aid kit is kept inside the glove box compartment.

The kit contains items that can be used in case of minor injuries only.

i NOTE

Examine contents of the first aid kit periodically and replenish consumed or expired items.

Tool Kit, Tow Hook, Jack And Spare Wheel

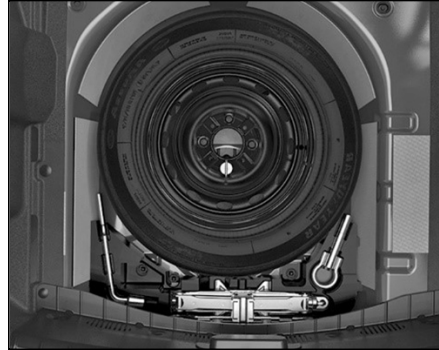

Tool kit & tow hook are kept inside luggage compartment near spare wheel.

i NOTE

The tool kit should be properly stored when not in use.

Jack

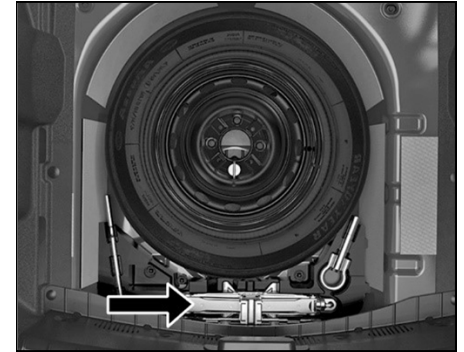

i NOTE

The jack should be used only to change wheels. It is important to read the instructions in this section before attempting to use the jack.

EMERGENCY AND BREAKDOWN ASSISTANCE

Advance Warning Triangle

An advance warning triangle is kept in the luggage compartment.

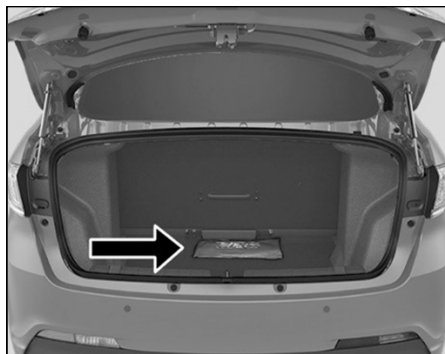

Use advance warning triangle to warn the approaching traffic in case of vehicle break-down or during emergency, where your vehicle could become a potential traffic hazard.



When you press the hazard warning switch, all turn signal lamps will start to blink.

Keep the warning triangle at an approximate distance of 50-150 m behind your vehicle in the same lane of traffic. The reflecting side of the triangle should face the oncoming traffic and it should be free from any obstacles.

Remove the advance warning triangle carefully from the bag and assemble. Refer instructions given on the bag.

i NOTE

After using the warning triangle tie it firmly and keep it inside the bag to avoid rattling noise.

Hazard Warning Switch



Press the hazard warning switch to activate the hazard warning. All the turn signal lamps will flash simultaneously. To turn OFF, press the switch again.

Use the hazard warning to warn the traffic during emergency parking or when your vehicle could otherwise become a traffic hazard.

The hazard warning lamps can operate even if the ignition is switched off.

SPARE WHEEL REMOVAL PROCESS

- To access the spare wheel, lift the carpet up.

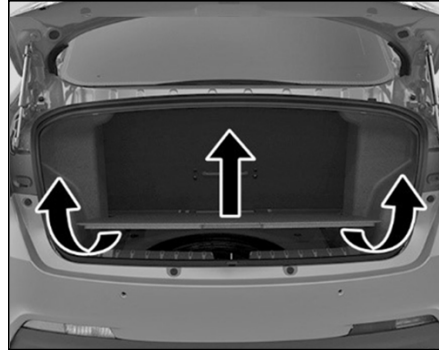

- After lifting, hold the carpet to access the spare wheel.



- To remove the spare wheel, unscrew and remove the retaining bolt.

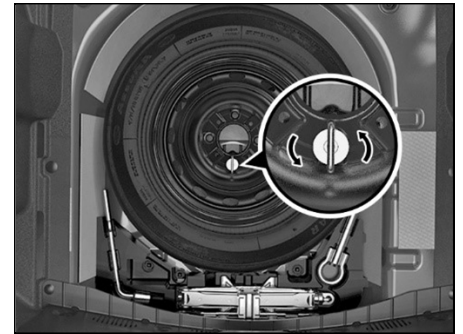

EMERGENCY AND BREAKDOWN ASSISTANCE

Following precautions are to be taken when temporary spare wheel is fitted on the vehicle.

WARNING

- Drive the shortest possible distances. The temporary spare wheel should be exchanged for a normal wheel as soon as possible. The temporary spare wheel is de-signed for a short period of use only.
- “80 km/h” or “50 mph” is the maximum speed you are permitted to drive with this tyre.
- Never drive faster than 80 km/h (50 mph). Do not accelerate quickly, brake suddenly or drive at high speed through bends.
- After fitting the temporary spare wheel, the tyre pressure must be checked as soon as possible.
- Recommended tyre pressure is 36 psi (2.5 bar) for temporary spare wheel.
-

- Snow chains cannot be used on the temporary spare wheel.
- Never use more than one temporary spare wheel.
- Do not drive through an automatic car wash.
- Never use a temporary spare tyre if it is damaged or worn down to the tread wear indicators.
- The ground clearance of your vehicle may be reduced. Take care when parking next to curb.
- The temporary spare should not be installed on the front axle if the vehicle must be driven in snow or on ice.
- Do not tow whilst the temporary spare wheel is installed.

NOTE

Your vehicle may exhibit some unusual driving characteristics when fit-ted with temporary spare wheel.

IN CASE OF FLAT TYRE

- Reduce vehicle speed gradually, Avoid sudden steering movement or braking.
- Pay attention to the traffic conditions as you do so.
- Switch on the hazard warning lamps.
- Stop the vehicle on solid, non-slippery and level ground, as far away as possible from traffic.
- Use the Jack on level, hard ground. Avoid changing the wheel on uphill and downhill slopes. Chock the wheels, if the deflated wheel needs to be changed on slope / ghat area.
- If possible, bring the front wheels into the straight-ahead position.
- Secure the vehicle against rolling away.
- Set the parking brake firmly and shift into “R” (Reverse) gear.
- Switch off the engine.
- Keep advance warning triangle at a suitable distance behind the vehicle as an indication of breakdown.

- Close all the doors.

WARNING

If you drive with a flat tyre, there is a risk of the following hazards:

- A flat tyre affects the ability to steer or brake the vehicle.
- You could lose control of the vehicle.
- Continued driving with a flat tyre will permanently damage the tyre and cause excessive heat buildup and possibly a fire. There is a risk of an accident.

Changing Flat Tyre

Loosen the nuts (as indicated) on the wheel in diagonal sequence. Do not unscrew the nuts completely before raising the vehicle using the jack.

Wheel nut removal

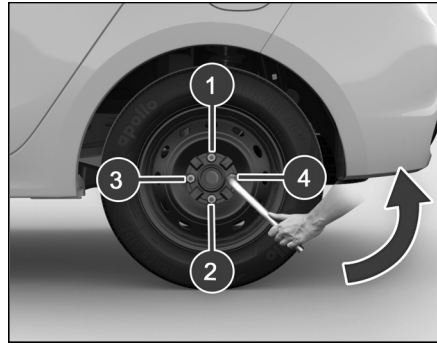

NOTE

- *The jack is designed only to raise and hold the vehicle for a short time while a wheel is being changed. It is not suited for performing maintenance work under the vehicle.*
- *Use the jack on level, hard ground. Avoid changing the wheel on uphill and downhill slopes. Chock the wheels, if the deflated wheel needs to be changed on slope / ghat area.*
- *Before raising the vehicle, secure it from rolling away by applying the*

parking brake.

- *Do not use wooden blocks or similar objects as a jack under-lay.*
- *Do not place your hands and feet or lie under the raised vehicle when it is supported by a jack.*
- *Do not run the engine when the vehicle is supported by the jack and never allow passengers to remain in the vehicle.*
- *Do not open or close a door or the tailgate when the vehicle is raised.*

Assemble the Jack handle and wheel spanner (as shown in fig.).

Position the jack vertically and raise it by turning the jack handle clockwise until the jack sits completely on the specified point and the base of the jack lies evenly on the ground.

The jack up points are indicated by cutouts on the front and rear.

EMERGENCY AND BREAKDOWN ASSISTANCE

Jack Up Point Location On Vehicle

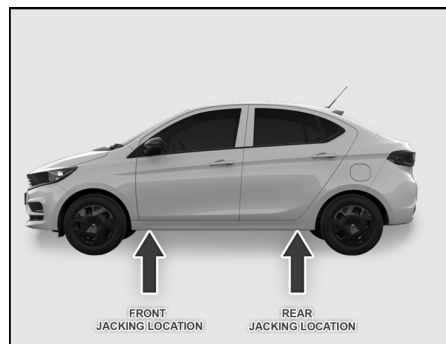

Jack up point location

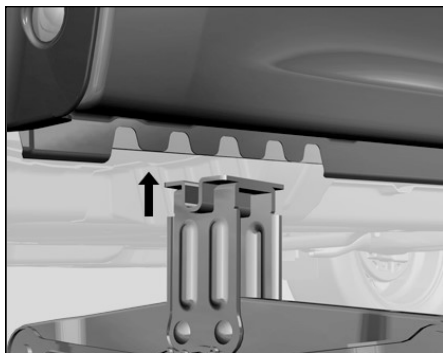

Front Jacking location

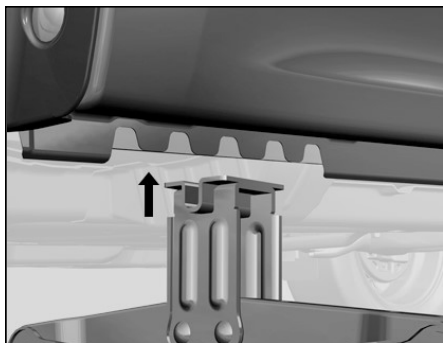

Rear jacking Location

WARNING

If you do not position the jack correctly at the appropriate jacking point of the vehicle, the jack could tip over with the vehicle raised. There is a risk of injury. Also jack can be damaged.

Continue to raise the jack slowly and smoothly until the tyre clears the ground. Do not raise the vehicle more than required.

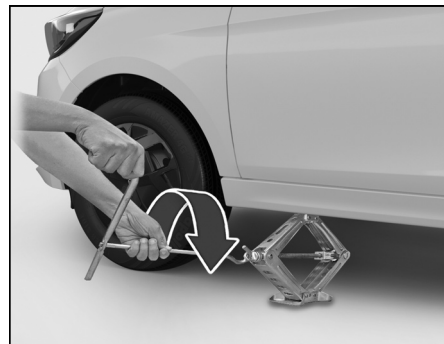

Remove wheel nuts with the help of wheel spanner and take out flat tyre.

i NOTE

Do not place wheel nuts in sand or on a dirty surface. Do not apply oil or grease on it.

Roll the spare wheel into position and align the holes in the wheel studs.

Tighten each nut by hand until the wheel is securely seated on the hub.

Lower the jack completely then tighten the wheel nuts one by one using wheel spanner.

Press fit the wheel cover back (if fitted).

Restore all the tools and jack at their respective locations.

Place the flat tyre at spare wheel location.

i NOTE

Do a check and correct the tyre pressure and wheel nuts tightness of the changed wheel at nearest authorised service station. Get the flat tyre repaired at the earliest

•

- *Place the jack only at recommended jacking locations.*

JUMP STARTING YOUR CAR

Use only a battery of same rating & capacity to jump start your vehicle. Position the booster battery close to your vehicle so that the jump leads will reach both batteries.

When using a battery of another vehicle, do not let the vehicles touch. Apply the parking brake firmly and keep the gearshift lever in neutral.

Turn off all vehicle accessories, except those necessary for safety like hazard warning lamps.

If your vehicle is equipped with Battery Sensor, then do not connect your jump start cable lead directly on the Sensor surface. Connect only on the negative cable surface as shown on the image. After jump start event, IAC function will be restored only when the Vehicle is parked in idle for 3-4 Hours.

EMERGENCY AND BREAKDOWN ASSISTANCE

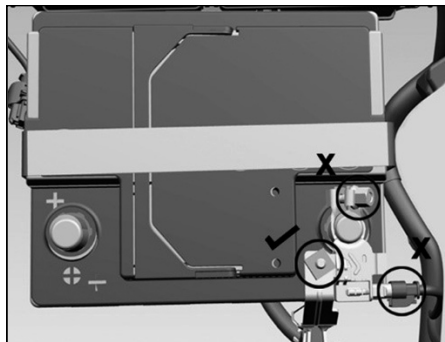

Make jump lead connections as follows:

- Connect one end of the first jump lead to the positive (+) terminal of the discharged battery.
- Connect the other end to the positive (+) terminal of the booster battery.
- Connect one end of the second jump lead to the negative (-) terminal of the booster battery.
- Make the final connection (other end of the negative terminal) to an unpainted, heavy metal part (i.e. engine mounting stud/nut) of the vehicle of discharged battery.

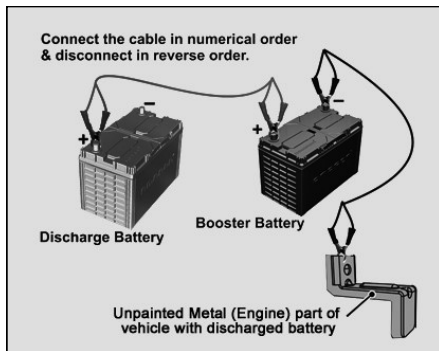

- Start the engine of the vehicle with the discharged battery.
- Before disconnecting the jumper cables, let the engine run for several minutes.
- If the booster battery you are using is fitted to another vehicle, start the engine of the vehicle with the booster battery. Run the engine at moderate speed.
- Remove the jump leads in the exact reverse order in which you connected them.

i NOTE

Do not disconnect the discharged battery from the vehicle.

⚠ WARNING

- Do not connect the jump lead directly to the negative (-) terminal of the discharged battery. This may lead to an explosion.
- Do not allow battery electrolyte to come in contact with eyes, skin, fabrics or painted surfaces. The fluid contains acid which can cause injury and severe damage. Wear protective apparel. Do not inhale any battery gases. Keep children away from batteries. In case if battery acid comes in contact with the skin, wash it off immediately with water and seek medical attention.
- During charging and jump-starting, explosive gases can escape from the battery. There is a risk of an explosion. Particularly avoid fire, open

flames, creating sparks and smoking. Make sure that there is sufficient ventilation while charging and jump-starting. Do not lean over the battery.

- Make sure that the positive terminal of a connected battery does not come into contact with vehicle parts. Never place metal objects or tools on a battery.
- It is important that you observe the described order of the battery terminals when connecting and disconnecting a battery. If you are in doubt, seek assistance from qualified specialist workshop.
- Do not connect or disconnect the battery terminals while the engine is running.

i NOTE

If your vehicle is equipped with a battery sensor, connect the jump start leads on output terminal of battery sensor. Do not

connect the jump start leads on sensor surface or battery terminal. This will result of function loss of battery sensor.

TOWING



When towing a break down vehicle, certain precautions and procedures must be taken to prevent damage to the vehicle and/or components. Failure to use standard towing precautionary measures when lifting or towing a break down vehicle could result in an unsafe operating condition.

To correctly tow and prevent accidental damage to your vehicle, take help of a TATA MOTORS Authorised dealer or a commercial tow-truck service.

EMERGENCY AND BREAKDOWN ASSISTANCE

NOTE

Make sure that the parking brake is released; vehicle is in neutral and steering wheel is unlocked. The power steering functions only when engine is running. Hence, during towing the steering efforts will be more.

WARNING

- Do not get under your vehicle after it has been lifted by a tow truck.
- For towing a vehicle, the best way is to use a wrecker. Alternatively use a rigid tow bar.
- Switch 'ON' the hazard warning indicators of both the vehicles to warn other road users.
- Limit the speed to 20-30 kmph.
- In case of brake failure, use the parking brake to control the vehicle.
- Fasten the tow rope or tow bar at the towing eyes. Otherwise, the vehicle could be damaged.

- When towing, pull away slowly and smoothly. If the tractive power is too high, the vehicles could be damaged.

Tow Hook Fitment

- Open the tailgate and remove tow hook from the tool kit.



- Open the tow hook cover provided on the front bumper by pressing it at the bottom part and simultaneously pulling it at the top (as shown in fig).



- Screw in and tighten the tow hook in clockwise direction.
- After towing, remove the towing hook and press fit the cover properly.
- Place the towing hook in the vehicle tool kit.

Recommended Towing

In case of break down, we recommend that your vehicle be towed with the driving wheels off the ground or place the vehicle on a flatbed truck as shown.

EMERGENCY AND BREAKDOWN ASSISTANCE

WARNING

- Do not tow your vehicle with the front wheels on the ground or four wheels on the ground (forward or backward), as this may cause serious damage to the transmission.
- When towing with the rear wheels on the ground or on towing dollies, place the ignition switch in the 'ACC' or 'ON' position, and secure the steering wheel in the straight-ahead position with a rope or similar device.

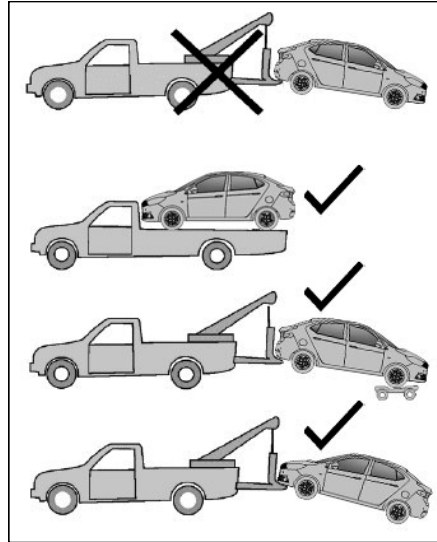

FUSES

Your vehicle has fuse boxes at three locations.

The vehicle's electrical circuits has fuses to protect the wiring from short circuits or sustained overload.

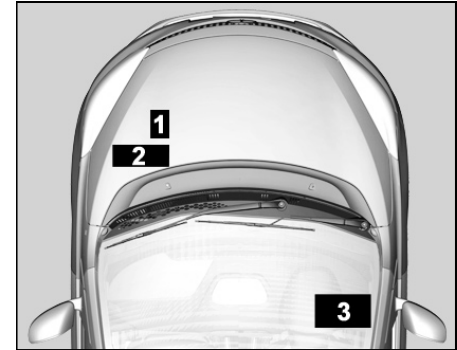

1. Battery Mounted Fuse Box.
2. Engine Compartment Fuse Box.
3. Cabin Compartment Fuse Box.

Checking and Replacing Fuses

If any electrical unit in your vehicle is not functioning, check the fuses first.

EMERGENCY AND BREAKDOWN ASSISTANCE

Please follow the steps below that will guide you to check and replace them.

- Apply parking brake
- Switch off all electrical accessories.
- Turn the ignition key to the 'LOCK' position.
- In the fuse box, identify the defective fuse from its melted wire.

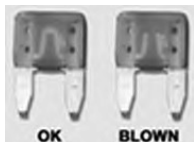

- Remove the defective fuse by "fuse puller". The fuse puller and spare fuses are provided in the engine compartment fuse box.

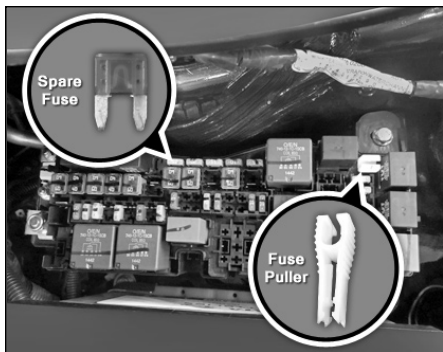

- Defective fuses must be replaced with fuses of same rating, which you can recognize by color and value.

i NOTE

Always make sure that the spare fuses are added.

- Make sure that all other fuses are pressed firmly in position.
- If a newly inserted fuse also blows, have the cause traced and rectified at nearest TATA MOTORS Authorized Dealer/Service Center immediately.

⚠ WARNING

- If you manipulate or bridge a faulty fuse or if you replace it with a fuse with higher amperage, the electric cables could be overloaded. This could result in a fire. There is a risk of an accident and injury.
- Always replace faulty fuses with the specified new fuses having the correct amperage.

Battery Mounted Fuse Box



EMERGENCY AND BREAKDOWN ASSISTANCE

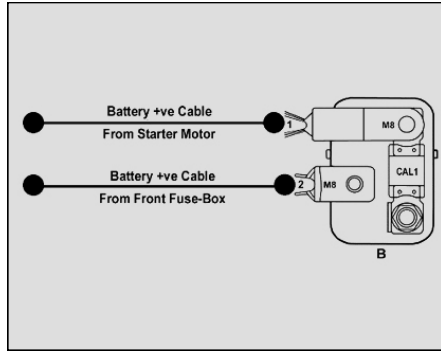

Fuse No	Function	Fuse Rating
PF1	Starter motor	CAL 1

⚠ WARNING

If fuse box cover is removed for any reason, it should be refitted properly in its original position.

Engine Compartment Fuse Box

Fuse No.	Function	Rating
F1	INTERIOR F/B 2 IGNITION	60A
F2	ABS/ESP ECU	40A
F3	-	-
F4	RADIATOR FAN	40A
F5	EPAS	60A
F7	INTERIOR F/B 1 BATTERY	60A
F8	EMS ECU MAIN RLY	30A
F10	IGNITION LOAD	60A
F11	TRANSMISSION CONTROL UNIT	30A
F12	COMPRESSOR	10A
F13	S T A R T E R SOLOINOID	25A
F14	ABS/ESP ECU	25A
F-15	HEAD LAMP LOW	15A
F-15	HEAD LAMP (HIGH/LOW BEAM)	20A
F16		15A

	HORN HIGH/LOW TONE	
F17	TRANSMISSION CONTROL UNIT	10A
F18	EMS BATTERY	10A
F19	HEAD LAMP HIGH	15A
F20	FUEL PUMP	15A
F21	IBS	5A
F22	H/L RLY COILS	5A
F23	CNG INJECTOR	10A
F24	FRONT WIPER MOTOR	20A
F25	ABS/ESP ECU IGN	5A
F26	CNG PRESSURE REGULATOR	5A
F27	TRANSMISSION CONTROL UNIT	10A
F28	REVERSE & BRAKE LAMP	10A
F29	REAR WIPER	10A
F38	EMS ECU SUPPLY	20A
F39	EMS SENSORS & RELAYS	15A
F40	PETROL INJECTORS	10A

EMERGENCY AND BREAKDOWN ASSISTANCE

F41	STARTER RELAY FEEDBACK	5A
F43	STOP LAMP	10A
F44	TPMS	5A
F45	RH HEAD LAMP & HL LEVELLING	10A
F46	LH HEAD LAMP & HL LEVELLING	10A

EMERGENCY AND BREAKDOWN ASSISTANCE

Fuse Box:

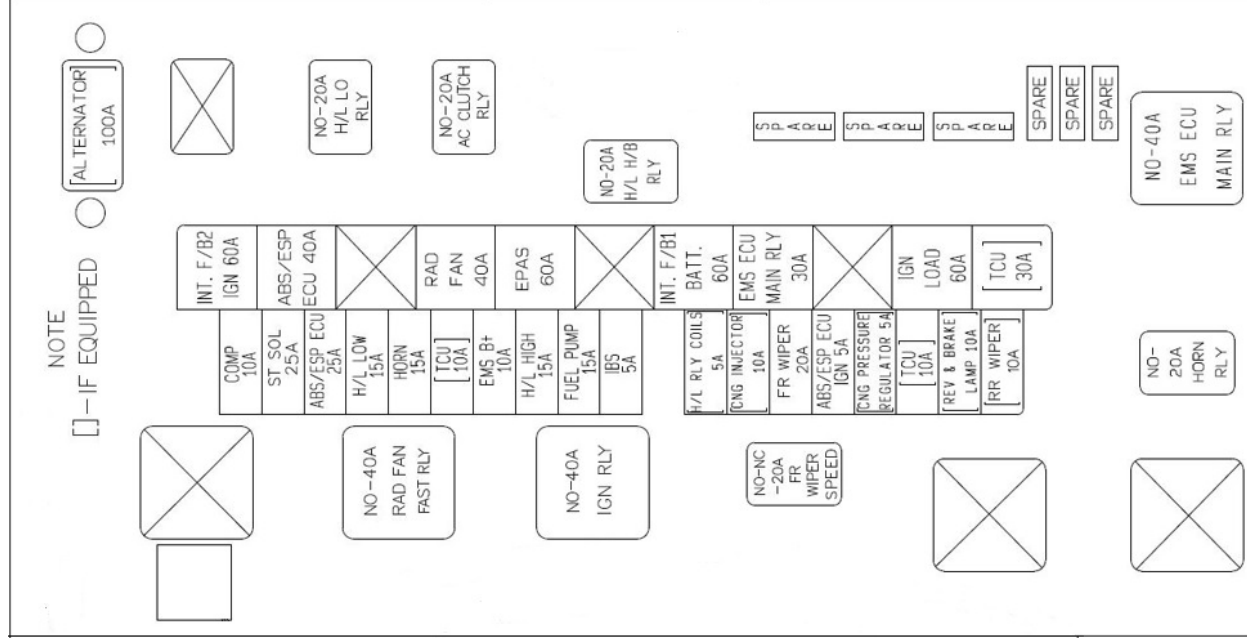

EMERGENCY AND BREAKDOWN ASSISTANCE

Relays:

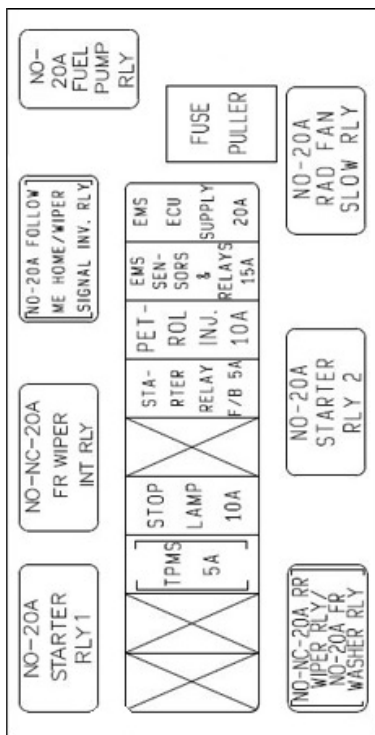

Relay No	Function	Rating
R1	--	--
R2	--	--
R3	STARTER RELAY 2	20A
R4	EMS ECU-MAIN RELAY	40A
R5	COOLING FAN (SLOW)	20A
R6	COOLING FAN (FAST)	40A
R7	INT WIPER (ON)	20A
R8	AC CLUTCH RELAY	20A
R9	--	--
R10	--	--
R11	FUEL PUMP	20A
R12	--	--
R13	HEAD LAMP (LOW BEAM)	20A
R14	HEAD LAMP (HIGH BEAM)	20A
R15	REAR WIPER RLY	20A
R16	HORN RELAY	20A
R17	IGNITION RELAY	40A
R18	FRONT WIPER SPEED	20A
R19	STARTER RELAY 1	20A

EMERGENCY AND BREAKDOWN ASSISTANCE

Fuse No.	Function	Rating
C115A F-1	BLOWER MOTOR	30A
C115A F-2	BCM	20A
C115A F-3	IGNITION SW	5A
C115A F-3	PEPS	10A
C115A F-4	PDC IGN /TELEMATICS IGN	5A
C115A F-5	REV LAMP & BRAKE SW	10A
C115A F-6	MODULE KL.15 I/P	10A
C115A F-7	RESTRAINTS CONTROL MODULE	10A
C115A F-8	EPAS	5A
C115B F-1	CDL	15A
C115B F-1	ACC-1	15A
C115B F-2	ACCESSORIES FUSE	5A
C115-B F-3	ITS	15A
C115B F-4	KEY IN	5A
C115B F-4	PEPS/BLOWER RLY	5A
C115B F-5	POWER SKT CONSOLE	15A
C115B F-6	ACC CONN. 2/OBD	15A
C115B F7	TRANSIST/INFOTAINMENT	15A/ 30A
C115B F-8	HEATED REAR SCREEN	25A
C115C F-1	BCM	20A

C115C F-2	CLUSTER	5A
C115C F-3	HVAC/FATC	10A
C115-D F-1	MIRROR ADJUST MOTOR	5A
C115-D F-2	C TYPE CHARGER	5A
C115-D F-3	POWER SOCKET FLOOR	15A
	FLOOR USB CHARGER	5A
C115-D F-4	TAILGATE LATCH	10A
C115-D F-5	BCM	20A
C115-D F-6	INFO DISPLAY	5A

EMERGENCY AND BREAKDOWN ASSISTANCE

BULB SPECIFICATION

Sn	Description	Rating	Type	Qty.
1	HIGH BEAM + LOW BEAM (option I)	12V, 55/60W	H19	2
2	HIGH BEAM (Option II)	12V, 55W	H7	2
	LOW BEAM (Option II)	12V,55W	H11	2
3	TURN SIGNAL FRONT	12V, 21W	PY21W	2
4	FOG LAMP FRONT	12V, 19W	H16	2
5	STOP + POSITION LAMP REAR	12V, 21/5W	P21/5W	2
6	POSITION LAMP FRONT	12V, 5W	W5W	2
7	TURN SIGNAL REAR	12V, 21W	PY21W	2
8	REVERSE LAMP	12V, 16W	W16W	2
9	REAR REGISTRATION PLATE LAMP	12V, 5W	W5W	2
10	SIDE REPEATER LAMP	12V, 5W	WY5W	2
11	ROOF LAMP	12V	LED	1
12	HIGH MOUNTED STOP LAMP	12V, 5W	W5W	5
13	POSITION LAMP REAR	12V,5W	W5W	2

EMERGENCY AND BREAKDOWN ASSISTANCE

24 X 7 ROADSIDE ASSISTANCE

Dear Customer,

It is our responsibility and our endeavor to ensure that you have our complete service backup if ever, wherever and whenever you need the same. When you have a road network that spans wide area, the probability of a breakdown happening within hailing distance of a TATA MOTORS Authorized Workshop is very low.

It is precisely for this reason, we have tied up with TVS AA, who will provide on-road services for repairable breakdown assistance including towing to the nearest TATA MOTORS Authorized Workshop through their Authorized Service Providers (ASP).

The 24X7 Roadside Assistance Program shall be automatically available to your vehicle for the duration of Warranty period. The program shall also be available, if you avail the same post warranty.

Response Time ** For The Roadside Assistance Program

Within City Limits	60 minutes
On State or National Highways	90 minutes
Ghat Roads and Hilly Terrain	120 minutes +/-
States of North-East, J&K and Himachal	Same Day (Within 24 Hrs)

** (The response time will depend on the location, terrain, traffic density and the time of the day.)

Standard Procedure When Calling For On-road Assistance In Case Of A Breakdown:

- Dial the toll free help line number – **1800 209 8282**
- Identify your vehicle with the Vehicle chassis number that is available in the Owner's Manual.
- Explain your exact location with landmarks and tell us about the problem you face with the vehicle.

- Park your vehicle on the edge of the road, open the bonnet and put on the hazard warning signal.
- Place the advance warning triangle supplied with the vehicle approx. 3 m from the vehicle in the direction of on-coming traffic.



Coverage Under 24 X 7 Roadside Assistance Program

- I. The **24x7 Roadside Assistance** Program Service covers the following services on your vehicle during warranty period.
- Wheel change through spare wheel.
 - Arrangement of fuel. (Fuel cost will be chargeable at actual cost).
 - Re-opening the vehicle in cases of key

EMERGENCY AND BREAKDOWN ASSISTANCE

lock out.

- Rectification of electrical problems related to battery, fuses etc.
- On spot repairs for complaints repairable at site. ^
- Vehicle to vehicle towing or winching & towing for non-accident cases up to the nearest TATA MOTORS Authorized Dealer/Service Center. Towing charges at actual cost beyond the same to be paid online to the ASP. (Any ferry or toll charges levied in relation to the vehicle being towed to be paid by the customers in actuals).

For accident cases, towing charges to be borne by the customer.

II. The **24x7 Roadside Assistance** Program coverage on availing the 24X7 policy, post warranty is upto maximum of 6 instance of assistance in one year for both the plans Basic and Premium. In the premium plan, this includes 2 instances of towing up to the nearest TATA MOTORS Authorized Dealer/Service Center.

Exclusions

24 X 7 Roadside Assistance Program Does Not Apply To

- Cost of parts consumables and labor for such repairs not covered under warranty*. These charges are to be settled with ASP in online.
- Toll or ferry charges paid by ASP in reaching to the breakdown site to be settled with ASP in actuals.
- Cases involving accident, fire, theft, vandalism, riots, lightening, earthquake, windstorm, hail, tsunami, unusual weather conditions, other acts of God, flood, etc.
- Vehicles that are unattended, un-registered, impounded or abandoned.
- Breakdown/defects caused by misuse, abuse, negligence, alterations or modifications made to the vehicle.
- Lack of maintenance as per the maintenance schedule as detailed in the owner's manual.
- Cases involving racing, rallies, vehicle testing or practice for such events.

Disclaimer

- The Service is not available in Lakshadweep.
- **The reach time is indicative & the actual reach time will be conveyed by the call center at the time of breakdown call.
- The reach time can vary depending on the traffic density & time of the day.
- The reach time indicated does not account for delays due to but not limited to acts of God, laws, rules & regulations for time being in force, orders of statutory or Govt. authorities, industrial disputes, inclement weather, heavy down pour, floods, storms, natural calamities, road blocks due to accidents, general strife and law & order conditions viz. fire, arson, riots, strikes, terrorist attacks, war etc.
- ^ On spot repairs at breakdown site shall depend on nature of complaints & will be as per the discretion of the ASP.
- * The decision for free of charge repairs will be as per the warranty policy

EMERGENCY AND BREAKDOWN ASSISTANCE

& procedures of TATA MOTORS PASSENGER VEHICLE LIMITED. and as per the interpretation of the same by ASP. You will be duly informed by the ASP & call center for the change applicable if any.

- All charges wherever applicable need to be settled directly with the ASP.

Exclusion Of Liabilities

- It is understood that TATA MOTORS shall be under no liability whatsoever in respect of any loss or damage arising directly or indirectly out of any delay in or non-delivery of, defect/deficiency in service/parts provided by ASP.
- In case vehicle cannot be repaired on-site, customers are advised to use the towing facility for taking their vehicle to the nearest TATA MOTORS authorized workshop only. In no condition shall the vehicle be towed to any unauthorized workshop. TATA MOTORS will not be responsible for any repairs carried out in such unauthorized workshop.

- Customer are advised to take acknowledgment from the ASP for the list of accessories/extra fittings and other belongings in the vehicle as well as the current condition related to dents/scratches break-ages of parts/fitments of the vehicle at the time of ASP taking possession of the vehicle & to verify these items when delivery is taken back by them, Claim for loss of or damage to items, if any should be taken up with ASP directly. TATA MOTORS shall not be responsible for any such claims, damages/loss or any deficiency of service of the ASP.
- Vehicles will be handled, repaired & towed as per the customer's risk & TATA MOTORS shall not be liable for any damages / claims as a result of the same.
- Services entitled to the customers can be refused or cancelled on account of abusive behavior, fraudulent representation, malicious intent and refusal to pay the charges for any charges related services and spare parts during service or on previous occasions on

part of the customer.

- On site repairs may be temporary in nature. The completion of repairs does not certify the road worthiness of the vehicle. The customer is advised to ensure temporary repairs carried out on-site is followed by permanent repairs at a TATA MOTORS Authorised Dealer/Service Center at the earliest. Terms and conditions and service coverage, exclusions etc. are subject to change without notice.

MAINTENANCE AND SERVICE

Periodic maintenance is essential for ensuring long trouble free performance.

Have your vehicle serviced regularly from TATA MOTORS Authorized Dealer/Service Center.

There is a large network of TATA MOTORS Authorized Service Centre to help you with their professional servicing expertise. Scheduled maintenance information is provided which makes tracking routine service easy.

The following checks can be carried out between the recommended scheduled maintenance services. Take help of our authorized service center for assistance.

- Engine oil level
- Engine coolant level
- Brake fluid level
- Washer fluid level checking & top-ping up
- Battery electrolyte level
- Tyre inflation pressure including spare wheel

NOTE

Refer "Opening and Closing" section for engine bonnet opening.

WARNING

- Be careful not to touch a hot engine, exhaust manifold and pipes, muffler, radiator and water hoses.
- Do not work on a vehicle with the engine running in an enclosed space, unless you are sure of enough ventilation.
- Keep all open flames and other burning material (such as cigarettes) away from the battery and all fuel related parts.

If you need to do any work inside the engine compartment,

- Switch off the ignition
- Never reach into the area where there is a risk of danger from moving components, such as the fan rotation area.
- Keep clothing away from moving parts.

MAINTENANCE

ENGINE COMPARTMENT – PETROL (MT)

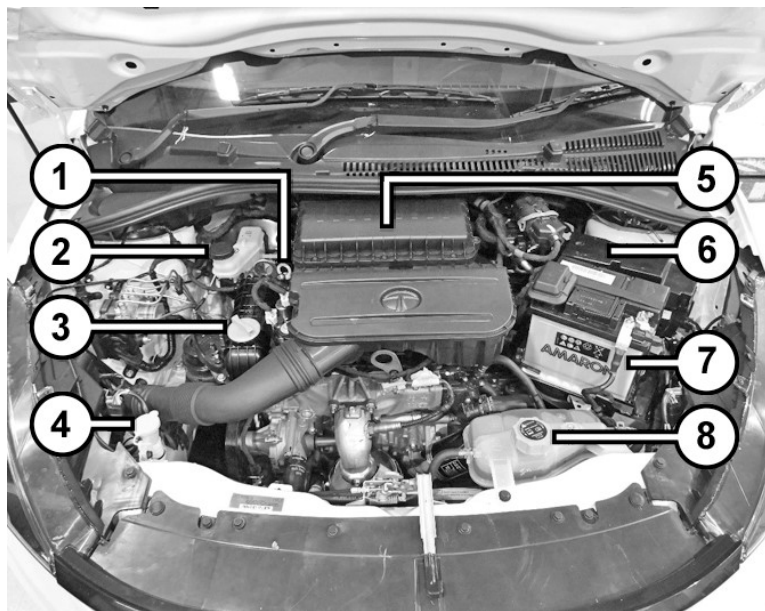

1. Dip Stick - Engine Oil
2. Brake fluid reservoir
3. Engine oil filling cap

4. Windshield washer container
5. Air Filter
6. Fuse & relay box

7. Battery
8. Auxiliary tank

ENGINE OIL LEVEL

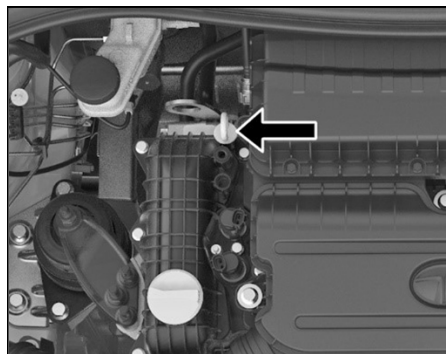

Dipstick location Engine oil (Petrol)

Warm up the engine to normal operating temperature.

Turn it 'OFF' and wait for 5 minutes for the oil to return to the oil pan. Be sure the vehicle is on a level surface.

Take out the dipstick, wipe it clean, and reinsert it fully. Pull it out again and examine the oil level. It should be between 'MIN' and 'MAX' level. If not, top up with recommended engine oil.

i NOTE

The oil consumption depends upon the driving style and the conditions under which the vehicle is used.

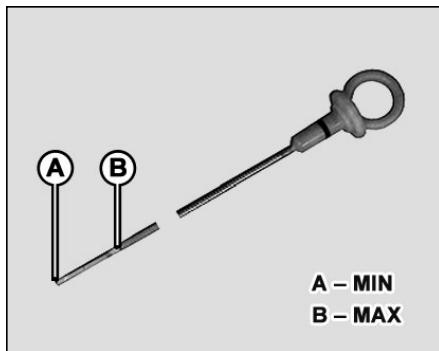

Dipstick (Petrol)

i NOTE

Do not remove the filler cap when the engine is running.

Do not add oil above than the MAX. mark. Oil level above the MAX. mark

may cause engine damage.

For location of Engine oil filling cap and dip stick, please refer image of the respective Engine Compartment.

MAINTENANCE

BRAKE FLUID LEVEL

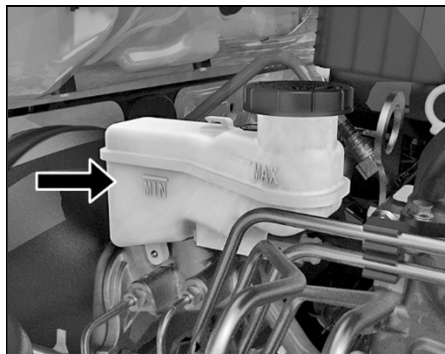

Brake fluid reservoir (Petrol)

The level of the brake fluid should be between the 'MIN' and 'MAX' marks provided on the side of the brake fluid container. If the level falls below the 'MIN' mark, add recommended brake fluid.

i NOTE

*Do not allow brake fluid to make contact with the skin or eyes.
Do not allow brake fluid to splash or spill on the paint surface as it will damage*

the paint. In case of spillage, wipe it off immediately.

For location of Brake Fluid Container and filling cap, please refer respective Engine Compartment.

ENGINE COOLANT LEVEL



Examine whether the coolant level is between the 'MIN' and 'MAX' marks provided on the coolant reservoir.

When the coolant level is low, top up with recommended coolant through filler of No loss tank until the level approaches the max level line. Refer 'Technical information' section.

i NOTE

In case of emergency, a large amount of water without engine coolant may be

added in order to reach a vehicle service location.

Whenever coolant has been added, the coolant level in the coolant reservoir should be checked the next few times you drive the vehicle to confirm correct level.

For location of Engine coolant container and filler cap, please refer image of Engine Compartment.

***i* NOTE**

Topping up of the coolant should be done in the auxiliary tank only.

Make sure that only TATA MOTORS recommended coolant is used. Mixing of different coolants may harm your engine's cooling system and its components. Do not add extra inhibitors or additives to the coolant. These can be harmful and compromise the corrosion protection of the engine coolant.

***⚠* WARNING**

The engine cooling system is pressurized, particularly when the engine is warm. When opening the cap, you could be scalded by hot coolant spraying out. There is a risk of injury. Let the engine cool down before opening the cap. Wear eye and hand protection when opening the cap. Open the cap slowly half a turn to allow pressure to escape.

WINDSHIELD WASHER FLUID LEVEL

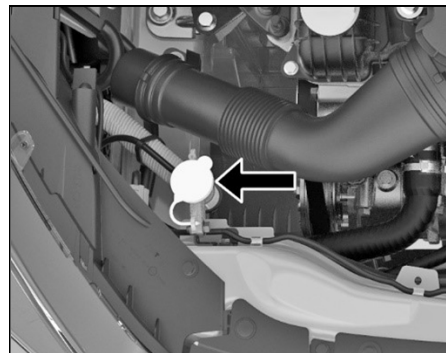

Examine if there is washer fluid in the tank. Fill it if necessary. Use a good quality windshield washer fluid, diluted with water as necessary.

***i* NOTE**

Do not use detergent or any other additive in the windshield washer reservoir. This can severely impair visibility when sprayed on the windshield, and can also damage your vehicle's paint.

MAINTENANCE

Do not operate washer motor with no fluid in washer tank, washer motor will be damaged.

For location of Windshield Washer Container and filling cap, please refer image of the respective Engine Compartment.

BATTERY

- Examine the battery for electrolyte level against the marking on the battery outer case.
- Examine the battery terminals for corrosion (a white or yellowish powder). To remove it, wash the terminals with a solution of baking soda. It will bubble up and turn brown.
- When this stops, wash it off with plain water. Dry off the battery with a cloth or paper towel.
- Apply petroleum jelly to the terminals to prevent further corrosion.
- Use a proper wrench to loosen and remove cables from the terminals.
- Always disconnect the negative (-ve) cable first and reconnect it last.
- If your vehicle is equipped with Battery Sensor, then disconnect only the Sensor Output Cable. Do not remove the Sensor, Sensor connector completely as this will result in the loss of sensor function temporarily. Sensor functionality will be restored when the Vehicle

is parked for 3 hours without any operation.

- Clean the battery terminals with a terminal cleaning tool or wire brush.
- Reconnect and tighten the cables, coat the terminals with petroleum jelly.
- Make sure that the battery is securely mounted.
- If you need to connect the battery to a charger, disconnect both cables to prevent damage to the vehicle's electrical system.
- If your vehicle is equipped with Battery Sensor, connect the jump start leads on output terminal of Battery Sensor. Do not connect the jump start leads on Sensor surface or Battery terminal. This will result of function loss of Battery sensor. Refer the Battery Sensor image for do's and don'ts.

For location of battery, please refer image of the respective Engine Compartment.

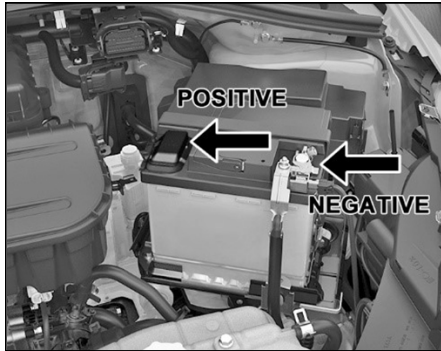

***i* NOTE**

Use only authorized Battery recommended by TATA MOTORS. Use of any other unauthorized battery will result into intelligent alternator control (IAC) function deterioration.

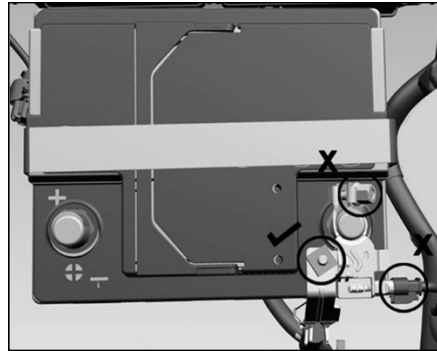

***i* NOTE**

- During normal operation, the battery generates gas which is explosive in nature. A spark or open flame can cause the battery to explode causing very serious injuries.
- Keep all sparks, open flames and smoking materials away from the battery.
- The battery contains sulphuric acid (electrolyte) which is poisonous and highly corrosive in nature. Getting

electrolyte in your eyes or on the skin can cause severe burns. Wear protective clothing and a face shield or have a skilled technician to do the battery maintenance.

MAINTENANCE

SPARK PLUG (PETROL)



Spark Plug	Number	Gap
Federal Mogul (Champion)	RER8MC	0.8 to 0.9 mm

Tightening Torque - 25 Nm

i NOTE

Use spark plug of recommended make & type for replacement.

TYRES

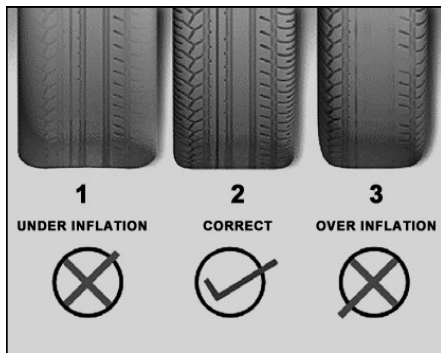

1	Under inflation	Excessive side tread wear
2	Correct tyre pressure	Uniform wear
3	Over inflation	Excessive center tread wear

Inflation

Do a check of the tyre pressure and the tyres condition periodically.

Examine the pressure in the tyres when they are cold.

Keep the correct pressure in the tyres for the best combination of riding comfort, handling, tyre life and optimum performance.

Over inflation of tyres makes the vehicle ride bumpy and harsh. Tyres are more prone to uneven wear and damage from road hazards.

Under inflated tyres reduce comfort, affects handling and increases the operating temperature, which can result in failure. They also cause uneven wear and bring down the performance of the car.

i NOTE

Every time you check inflation pressure, you should also examine tyres for uneven wear, damage and trapping of foreign objects in the treads and wear.

Recommended Tyre Pressures

Tyre Size	Version	Front (psi/b ar)	Rear (psi/b ar)	Spare
175/65 R14	Petrol	33 / 2.28	30 / 2.07	36 / 2.48
175/60 R15		36 / 2.48	36 / 2.48	36 / 2.48
155/80 R13		NA	NA	36 / 2.48

***i* NOTE**

- Maintain tyre inflation pressure as per the specific mentioned in tyre pressure sticker.
- Regular tyre and spare tyre to be checked for correct tyre inflation pressure at least once a month.

Tyre Pressure Sticker Location

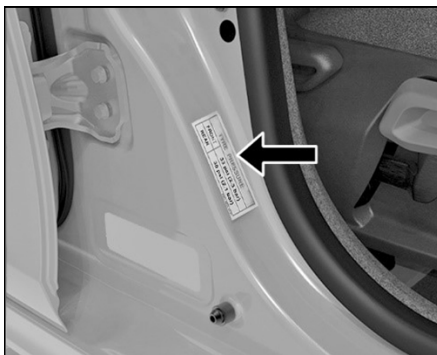

Tyre Rotation

To increase tyre life rotate the tyre at specified intervals or earlier depending on the operation of vehicle. The illustrations shows how to rotate tyres.

For 175/65 R14 and 175/60 R15 tyres with temporary spare wheel (if equipped)

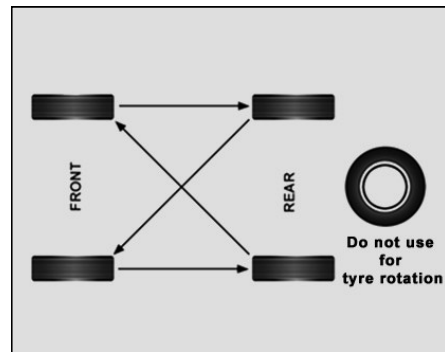

***i* NOTE**

- Do not use spare wheel for tyre rotation, in case of temporary spare wheel used.
- Two or more temporary tyres should not be used on one vehicle.
- Tyre pressure of temporary wheel is to be checked at least once in in a month.

MAINTENANCE

Wheel Alignment

Incorrect wheel alignment causes excessive and uneven tyre wear. Check wheel alignment at specified intervals.

Wheel Balancing

Wheels of your vehicle are balanced for better ride comfort and longer tyre life. If the vehicle experiences abnormal vibration on a smooth road, have the wheels balanced immediately at the nearest TATA MOTORS Authorized Service Center.

Wheel Cover

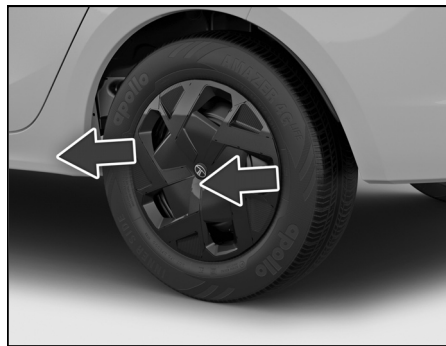

Insert a piece of cloth between the spokes

of the wheel cover and pull it outwards. Take out detached wheel cover from the wheel rim.

When installing the cover, make sure that it is positioned so that it does not cover the air filling valve. Apply equal pressure at the circumference of the wheel cover to fix it in the wheel rim.

i NOTE

Do not use any sharp tools (such as screw driver etc.) to remove the wheel cover.

Special Care For Tubeless Tyres:

- When you remove the tyre and in-stall it back on the rim, take precautions not to damage tyre bead. Use tyre removal and assembly machines. Damage or cut on tyre bead may cause gradual loss of air and deflation of tyre.
- Do not scratch the inner surface of tubeless tyre with metallic or sharp object. Tubeless tyres are coated with impermeable layer of rubber from the inner surface which holds the air in the

tyre. Removal of this layer due to scratching may cause gradual loss of air and deflation.

- If wheel rim gets damaged in service, get the wheel rim repaired/ replaced immediately. Running the vehicle with damaged rim may cause deflation of tyre and subsequent dislodging of tyre from rim.
- Keep the recommended inflation pressure. Over-inflation, in particular, may cause puncture or bursting of tyre.

i NOTE

Life and wear pattern of tyres depends on various parameters like tyre pressure, wheel alignment, wheel balancing, tyre rotation, etc. It also largely depends on vehicle speed, load carried, usage, driving habits, road conditions, tyre quality, etc. In case fault is suspected to be due to poor quality of tyres, the same may be taken up with concerned tyre manufacturer.

REMOTE KEY BATTERY REPLACEMENT

Remote control key contains a battery which is housed under the cover.

If red LED remote flashes for 5 times after placing and releasing any button on remote. It is recommended to replace battery at a TATA MOTORS Authorised Service Centre.

You should, however, proceed as follows if you wish to replace the discharged battery yourself:

1. Open the key blade.
2. Press off the battery cover with your thumb or using a flat screw driver at the points of the arrows.
3. Remove the discharged battery from the key by pressing the battery downwards at the point of the arrow.



4. Insert the new battery.

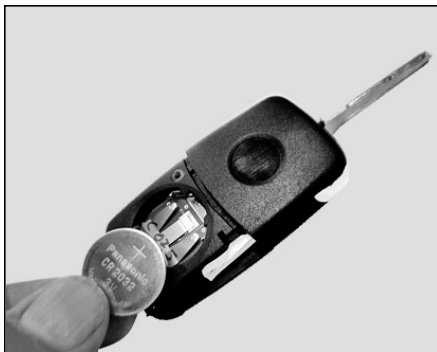

5. Ensure that the "+" symbol on the battery is facing upwards. The correct polarity is shown on the battery cover.
6. Position the battery cover on the key and press on it until it is heard to lock in place.

NOTE

- Use CR 2032 battery only.
- An inappropriately dis-posed battery can be harmful to the environment and human health. Dispose the battery according to your local law(s) and regulation.

MAINTENANCE

ON BOARD DIAGNOSTIC (OBD II) SYSTEM

On board Diagnostics or OBD, is an automotive term referring to a vehicle's self-diagnostic and reporting capability. The OBD system allows continuous diagnosis of the components of the vehicle correlated with emissions. This system warns the driver, by turning "ON" the Malfunction Indication lamp (MIL) on the instrument cluster, when a fault causes emission levels to increase.

The OBD system also has a diagnostic connector that can be interfaced with appropriate diagnostic tools, which makes it possible to read the fault codes stored in the Electronic Control Unit, together with a series of specific parameters for Engine operation and Diagnosis. This check can also be carried out by the traffic police.

To access the diagnostic connector, open the fuse box cover which is located on RH side below the steering wheel.

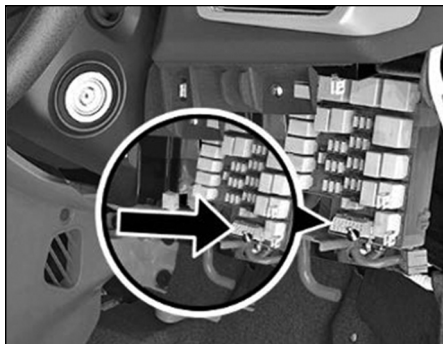

Location of On board diagnostic (OBD II).

SERVICE INSTRUCTIONS

The **TATA XPres-T** has been manufactured to give you economical and trouble free performance. To achieve this, please follow the instructions as stated.

Your vehicle is entitled to three free services (labour only). The free service coupons are attached to the sales invoice. Please present these coupons to the servicing dealer while availing free services.

1st free service - At 1,000-2,000km. OR 2 months, whichever is earlier.

2nd free service - At 4,500-5,500km. OR 6 months, whichever is earlier.

3rd free service - At 9,500-10,500km. OR 12 months, whichever is earlier.

All services other than free services are chargeable.

Servicing of the vehicle can be done at any TATA MOTORS Authorised Dealer Workshop or TATA MOTORS Authorised Service Centre (TASC).

Warranty claims can be settled by any TATA MOTORS Authorised Dealer Workshop or TATA MOTORS Authorised Service Centre (TASC).

MAINTENANCE

SERVICE SCHEDULE

Note: 1. Vehicle operating in Severe Driving Conditions, conditions are given at the end of this schedule

2. Beyond 150000 carry out the same services at the same intervals of 10000 kms respectively

Periodic Maintenance Schedule		Free Service			Paid Service													
Service Intervals In Km (kilometer) Or Months Whichever Comes Earlier	Km	1000	5000	10000	20000	30000	40000	50000	60000	70000	80000	90000	100000	110000	120000	130000	140000	150000
	Months	2	6	12	24	36	48	60	72	84	96	108	120	132	144	156	168	180
I: Inspect (Check, Clean, Correct, Top Up, Adjust, Repair, Replace As Necessary) T: Tightening Torque R: Replace																		
S N	GENERAL																	
1	Inspect & top up fluids (If required): transaxle oil, coolant, brake fluid, battery electrolyte, wind screen washer fluid	I	I	I	I	I	I	I	I	I	I	I	I	I	I	I	I	I
2	Inspect fuel lines for leakages	I	I	I	I	I	I	I	I	I	I	I	I	I	I	I	I	I
3	Check if any Tell Tale Lamp is ON	I	I	I	I	I	I	I	I	I	I	I	I	I	I	I	I	I
4	Inspect all door latches & striker operations, apply grease if required.			I	I	I	I	I	I	I	I	I	I	I	I	I	I	I
5	Inspect Auxillary belt condition , engine mount, rubber boots, rubber seal, exhaust hanger, dust cover & bushes for any damages	I	I	I	I	I	I	I	I	I	I	I	I	I	I	I	I	I

MAINTENANCE

Periodic Maintenance Schedule		Free Service			Paid Service													
Service Intervals In Km (kilometer) Or Months Whichever Comes Earlier	Km	1000	5000	10000	20000	30000	40000	50000	60000	70000	80000	90000	100000	110000	120000	130000	140000	150000
	Months	2	6	12	24	36	48	60	72	84	96	108	120	132	144	156	168	180
I: Inspect (Check, Clean, Correct, Top Up, Adjust, Repair, Replace As Necessary) T: Tightening Torque R: Replace																		
6	Check condition of rubber bushes/parts of front & rear suspension in control arms/linkages/RTB, front and rear coil spring seats, front & rear bump stoppers, anti roll bar, stab links, rubber boots/dust cover/bellow in rack & pinion, steering and suspension ball joints, steering column. Replace if necessary. (First at 10K / 12M then at every service). For severe usage, above checks to be done at every 5,000 km or after every severe usage event			T	T	T	T	T	T	T	T	T	T	T	T	T	T	T
7	Check for all bolts & nuts (Tighten). For severe usage, above checks to be done at every 5,000 km or after every severe usage event			T	T	T	T	T	T	T	T	T	T	T	T	T	T	T
S N	ENGINE (Petrol)																	
1	Air filter element			Inspect at every Service Replace at every 50000 km/36 Months														
2	Engine oil and oil filter			R	R	R	R	R	R	R	R	R	R	R	R	R	R	R

MAINTENANCE

Periodic Maintenance Schedule		Free Service		Paid Service														
Service Intervals In Km (kilometer) Or Months Whichever Comes Earlier	Km	1000	5000	10000	20000	30000	40000	50000	60000	70000	80000	90000	100000	110000	120000	130000	140000	150000
	Months	2	6	12	24	36	48	60	72	84	96	108	120	132	144	156	168	180
I: Inspect (Check, Clean, Correct, Top Up, Adjust, Repair, Replace As Necessary) T: Tightening Torque R: Replace																		
3	Fuel Filter-(Integrated in FDM)	Replace Every 80,000 km/ 60 Months whichever comes earlier																
4	Spark plugs	Replace Every 40,000 km/ 36 Months whichever comes earlier																
5	Engine coolant	Replace Every 60,000 km/ 36 Months whichever comes earlier																
S N	TRANSAXLE (Petrol & Diesel)																	
1	Transaxle oil	Replace Every 80,000 km/ 60 Months whichever comes earlier																
S N	BRAKES																	
1	Inspect Front brake pads,rear brake linings.disk/drum																	
2	Brake/ clutch fluid	Replace Every 50,000 km/ 24 Months whichever comes earlier																
3	Adjust handbrake setting																	
S N	WHEELS & TYRES																	
1	Check & adjust wheel alignment(For severe usage, above checks to be done at every 5,000 km or after every severe usage event)																	

Periodic Maintenance Schedule		Free Service			Paid Service													
Service Intervals In Km (kilometer) Or Months Whichever Comes Earlier	Km	1000	5000	10000	20000	30000	40000	50000	60000	70000	80000	90000	100000	110000	120000	130000	140000	150000
	Months	2	6	12	24	36	48	60	72	84	96	108	120	132	144	156	168	180
I: Inspect (Check, Clean, Correct, Top Up, Adjust, Repair, Replace As Necessary) T: Tightening Torque R: Replace																		
2	Inspect Tyre pressure, Condition for abnormal wear/crack and do Tyre rotation		I	I	I	I	I	I	I	I	I	I	I	I	I	I	I	I
S N	ELECTRICAL																	
1	Specific gravity of battery electrolyte, battery SOC		I	I	I	I	I	I	I	I	I	I	I	I	I	I	I	I
2	Check External and internal lights, horn,wiper and Cluster operations			I	I	I	I	I	I	I	I	I	I	I	I	I	I	I
S N	A.C. SYSTEM																	
1	Inspect air-conditioning performance	I	I	I	I	I	I	I	I	I	I	I	I	I	I	I	I	I

Severe conditions are as below -

Under severe driving conditions additional maintenance is required:

- A: Driving in conditions such as patrolling, Pickup Van, Vehicle Towing, trailer towing
- B: Driving on rough, sandy, dusty, muddy, unpaved, graveled or salt-spread roads.
- C: More than 50% (in terms of Km) driving in heavy city traffic in stop and go condition

MAINTENANCE

D: Frequently operating in mountainous area, uphill, downhill

E. Repeatedly driving short distance of less than 7 km.

F: Extensive low speed driving for long distance

Item	Interval	Condition					
		A	B	C	D	E	F
Engine oil and oil filter	Replace every 5000 Km	R	R	R	R	R	R
Check and adjust wheel alignment	Inspect every 5000 km	I	I	I	I	I	I
Air Filter	Inspect every 5000 km	I	I	I	I	I	I

NOTE

- *In Free service, labor charges are free, any parts and consumables will be chargeable.*
- *Filters, Fluid, Consumables, Grease, Components, wheel alignment Wheel Balancing and weights etc will be replaced on chargeable basis.*
- *Check the coolant level and top up as required, replace if it is contaminated /discolored or there is sludge formation.*
- *Periodic maintenance Schedule is for reference. TMPV reserves the rights to change the Periodic Maintenance Schedule*

VEHICLE PARKING FOR LONG DURATION (NON - USE MAINTENANCE)

If you want to park your vehicle at one place for long duration, following care is to be taken:

1. Park the vehicle in covered, dry and if possible well-ventilated premises. Engage a gear.
2. Remove the battery terminal cables (first remove the cable from the negative terminal). Ensure that battery is fully charged.
3. Use wheel chocks to prevent movement of the car.
4. Clean and protect the painted parts using protective wax.
5. Clean and protect the shiny metal parts using commercially available special compounds.
6. Sprinkle talcum powder on the rubber windscreen wiper and lift them off the glass.
7. Slightly open the windows.
8. Cover the vehicle with a cloth or perforated plastic sheet. Do not use sheets of imperforated plastic as they do not allow moisture on the vehicle body to evaporate.
9. Inflate the tyres to 0.5 bar above the normal specified pressure and check it at regular intervals.
10. Check the battery charge every six weeks.
11. Do not drain the engine cooling system.
12. Always park your vehicle in shade do not expose the vehicle to direct sunlight for extended period of time.
13. Extended exposure to sunlight may deform plastic parts like dashboard, leather surface etc.
14. Item like cigarette lighter, perfume spray, soft drink can kept inside the vehicle in direct sunlight may result in fire explosion etc.
15. Do not park your vehicle for long duration in front of glass building where direct sunlight is exposed on the glass

which reflects and may transfer the heat on vehicle. In this case plastic parts may melt.

FUEL SPECIFICATION

Fuel (Petrol)

Always use only unleaded fuel having an Octane Rating 91 / AKI (Antiknock Index) 87 or higher. Your vehicle is equipped with E20 compatible fuel system materials. It is recommended to use Petrol, Ethanol blends upto 20% only. Make sure those blended fuel has no lower Octane Rating as recommended for Petrol.

i NOTE

Never use leaded fuel. This could deteriorate catalytic converter and damage emission control system and affect the environment.

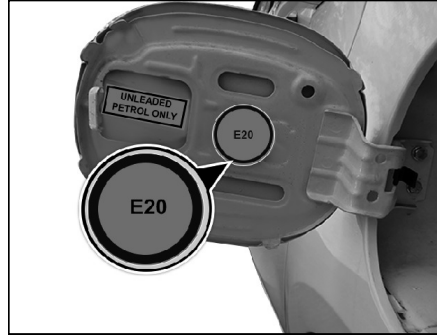

TECHNICAL INFORMATION

LUBRICANT SPECIFICATION

Use following genuine fluids, coolants and lubricants recommended for optimum performance of your vehicle.

Item	Specification	Company	Brand	Quantity
Engine Oil	0W20 LOW ASH BS VI SS6588	CASTROL	Magnatec Professional T 0W20	Petrol – 4 L
		EXXON MOBIL	Mobil super 3000 TMGO 0W20 Tata motors genuine oil	
		PETRONAS	TATA MOTORS GENUINE OIL – Engine Oil synth 0W20	
Coolant (Pre-mixed) (Antifreeze agent + Soft water 40 : 60 ratio)	Class II/JIS K2234 TATA SS7700S1	Sunstar CCI	Gloden Cruiser LLC2200NP	Petrol – 4 L
		CASTROL	Castrol Radicoolant SFO Premix	
Transaxle Oil	SAE75W70 SS6595	PETRONAS	TATA MOTORS Genuine Oil – Gear Oil New Gen 80 EP LL	1.7 Liters
		IOCL	TATA MOTORS GENUINE GEAR OIL 80WLL	
		CASTROL	Transmax Manual T 80W	
Brake Fluid/Clutch fluid	DOT4 SAE J1703, SAE J1704	PETRONAS	Tutela Brake fluid DOT 4	As required
		Sunstar CCI	Golden Cruiser Tata Genuine Brake Fluid (DOT4)	
		CASTROL	Optional - CASTROL- Universal Brake Fluid DOT 4	
Refrigerant	R-134a	-	-	600±20 gms
Compressor Oil	SP-10	Sandan Vikas	-	120±15 cc

TECHNICAL SPECIFICATIONS

Parameter	Petrol
Engine	
Model/type	REVOTRON, 1.2L
Capacity	1199 CC
Max. Engine output	63 kw @ 6000 rpm
Max. Torque	113 Nm @ 3300 +/-100 rpm
Clutch	
Type	Dry, Single Plate
Outside diameter of clutch	200 mm
Transaxle	
Model	TA-65* 5/3.64 (5 speed) with overdrive manual
Type	Synchromesh on all forward gears and sliding mesh on reverse gear
No. of gears	5-Forward, 1-Reverse
Steering	
Type	Electrical Power assist Steering
Brakes	
Brakes	Front (Disc); Rear (Drum)
Parking brake	Cable Operated Mechanical (Variable Lever Ratio)
Suspension	
Type	Independent, Lower wishbone, McPherson Strut with coil spring (front) Semi-independent; closed profile Twist beam with Dual path Strut (rear)

TECHNICAL INFORMATION

Parameter	Petrol
Shock absorber	Double acting telescopic type, Hydraulic, Gas filled
Wheels & tyre	
Tyres	Option I:175/65 R14 82T (Radial tubeless tyre) Option II:175/60 R15 81H (Radial tubeless tyre)
Wheel rims	Opt. I :5J x 14" Opt .II : 5.5J x 14" Hyper style Wheel Rim Opt .III : 5.5J x 15"
Fuel tank	
Capacity	35 liters
Cab / body	
Type	Semi-mono volume, 4 doors sedan, steel monocoque body.
Electrical system	
System voltage	12 Volts (-ve earth)
Alternator capacity	110 Amp
Battery	12V, 52Ah
Main chassis dimension (in mm)	
Wheel base	2450
Track front	1400
Track rear	1420
Overall length	3993
Overall height	1532
Max. Width	1677

TECHNICAL INFORMATION

Parameter	Petrol
Ground clearance	134 (laden)
Performance	
Max. Speed	160 Kmph
Max. Recommended gradability	14 deg
Minimum Turning Circle Dia.	10.1 m
Minimum Turning Clearance circle Dia.	11 m
Weight (in kg)	
Gross vehicle weight	1395-1433
Kerb weight (Unladen)	995-1033

TECHNICAL INFORMATION

VEHICLE DIMENSIONS

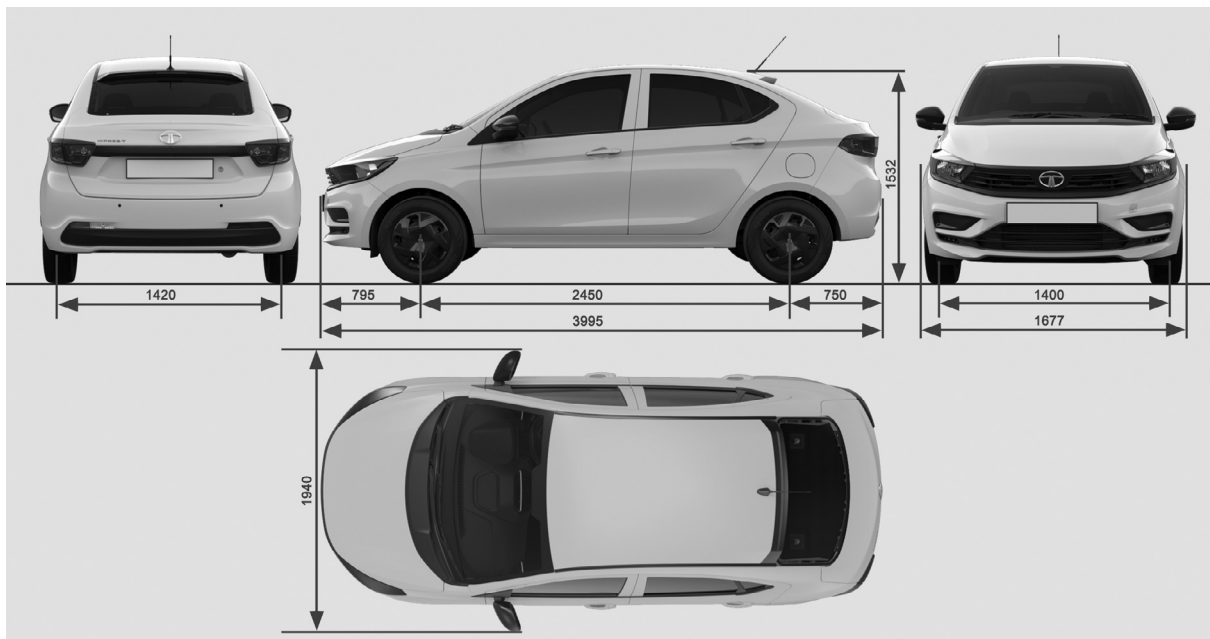

NOTE: Dimensions are in mm Laden/Unladen condition

**AGGREGATE IDENTIFICATION
NUMBERS**

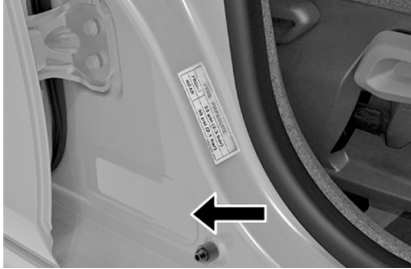

Chassis No. punching near driver seat

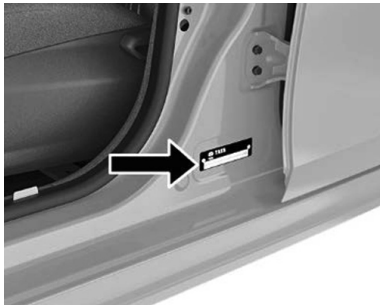

VIN plate location near front passenger seat

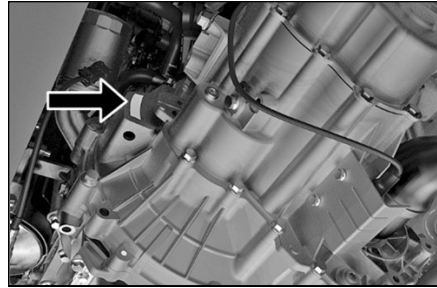

Transaxle No. Punching (TA 65*)

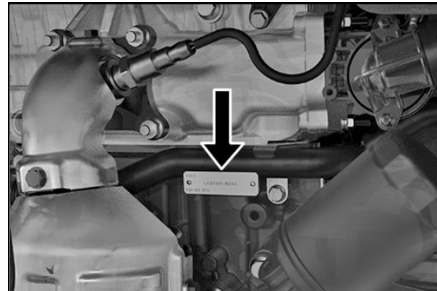

Engine No. plate Petrol

CAR CARE

Your vehicle is subjected to many external influences such as climate, road conditions, industrial pollution and proximity to the sea. These conditions demand regular care of the vehicle body. Dirt, insects, bird droppings, oil, grease, fuel and stone chip-pings should be removed as soon as possible.

Washing

Following these tips while washing your vehicle.

1. Always wash your vehicle in shade and ensure surface is at room temperature.
2. Wash with mild vehicle wash soap like 'Car Shampoo' and use a soft bristle brush, sponge or soft cloth and rinse it frequently while washing to avoid scratches.
3. When cleaning ensure that drain holes of lower door panels and rocker panel are free from mud, slug etc to make way for entrapped water inside it to avoid corrosion.
4. To avoid scratches, please wear soft gloves. Remove finger rings, nails, wrist watch while washing.
5. To remove stubborn stains and contaminants like tar, use turpentine or cleaners like 'Stain remover' which are safe for paint surfaces.
6. Avoid substances like petrol, diesel, kerosene, benzene, thinner, acids or other solvents that cause damage to vehicle interior, exterior and paint.
7. Dry your vehicle thoroughly to prevent any damp spots.
8. Rinse all surfaces thoroughly to prevent any traces of soap and other cleaners as this may lead to the formation of stains on the painted surface later.
9. During washing of the vehicle, do not apply water jet OR pressure water from pipe directly on any rubber material or Seal surface. This is to avoid damage to Rubber sealing parts in the sunroof system or in the vehicle. The damage to the sunroof sealing or any other seal in the vehicle will cause

water ingress inside the vehicle.

10. It is recommended to use dry low pressure air for cleaning the engine compartment. Do not use pressurized water.

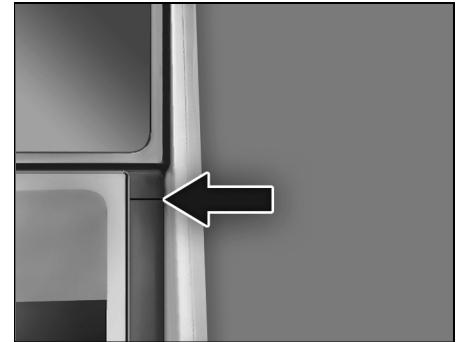

NOTE

- *Avoid parking the car under trees without proper cover, it will reduce the amount of bird droppings, tree sap and pollen contact on paint surface. Regularly remove the twigs, leaves and vegetation near the*

CAR CARE AND VALUE ADDED SERVICES

windshield areas, to avoid water stagnation.

- Always close the sunroof while washing the vehicle.

WARNING

Do not direct high pressure washer fluid/ water jets (Pressure above 0.5 bar) at electrical devices and connector during washing. This is to prevent malfunction / failure of electrical system due to water ingress.

After drying the vehicle, inspect it for chips and scratches that could allow corrosion to start. Apply touch up paint where necessary.

Cleaning of Carpets

Vacuum clean the carpet regularly to remove dirt. Dirt will make the carpet wear out faster. Periodically, shampoo the carpet to keep it looking new.

Use carpet cleaners (preferably foam type). Follow the instructions that come with the cleaner. Apply it with a sponge or

soft brush. Keep the carpeting as dry as possible by not adding water to the foam.

NOTE

Avoid wiping of painted surface in dry condition as it may leave scratches on the painted surface.

Cleaning of Windows, Front and Rear Glasses

Clean the windows inside and outside with commercially available glass cleaners.

This will remove the haze that builds up on the inside of windows. Use a soft cloth or paper towels to clean all glass and plastic surfaces.

Waxing

Waxing and polishing is recommended to maintain the gloss and wet-look appearance of your paint finish.

1. Use good quality polish and wax for your vehicle.
2. Re-wax your vehicle when the water does not slip off the surface but collects over the surface in patches.

Polishing

Polishes and cleaners can restore shine to the painted surface that has oxidized and become dull. They normally contain mild abrasives and solvents that remove the top layer of the finish coat. Polish your vehicle, if the finish does not regain its original shine after using wax.

Interior Fabric Cleaning Tips

1. Stains should be treated immediately. If left for a long time, they can leave a permanent mark.
2. Cleaning the stains immediately is important especially for stains, which contain artificial colors in the stain creating liquid or semisolid substance. The colorant may leave a stain if kept for longer time.
3. Stain should not be removed by rubbing. As far as possible, try to blot or lift the stain with cloth or plastic spatula and then clean the remaining stain with cloth or sponge.
4. If the stain has dried, then gently brush off the material and then press with

- damp cloth or sponge till it disappears.
- Do not use household detergents to clean the fabric.
 - Always use clean cotton cloth for cleaning.

Paint Care

Following guidelines will help you to protect your vehicle from corrosion effectively.

NOTE

Avoid Spillage or Direct contact of Air freshener liquid/chemicals with painted plastic parts. These chemicals may cause damage to paint like blisters, peel off, wrinkles etc

Proper Cleaning

- In order to protect your vehicle from corrosion it is recommended that you wash your vehicle thoroughly and frequently in case:
- There is a heavy accumulation of dirt and mud especially on the underbody.
- It is driven in areas having high atmospheric pollution due to smoke, soot,

dust, iron dust and other chemical pollutants.

- It is driven in coastal areas.
- The underbody must be thoroughly pressure washed after every three months.
- In addition to regularly washing your car, the following precautions need to be taken.

Periodic Inspection

- Regularly inspect your vehicle for any damage in the paint film such as deep scratches and immediately get them repaired from an authorized service outlet, as these defects tend to accelerate corrosion.
- Inspect mud liners for damages.
- Keep all drain holes clear from clogging.

Proper Parking

Always park your vehicle in shade to protect it from harsh sunlight or in a well-ventilated garage so that there is no dampness on any part of the vehicle.

Wiper Care

To prevent damage to the wipers or windshield, do not operate the wipers when the windshield is dry.

To prevent damage to the wiper arms and other components, do not attempt to move the wipers manually

CAR CARE AND VALUE ADDED SERVICES

VALUE CARE - AMC

Value Care (AMC) is a fixed cost maintenance plan that guarantees protection against unexpected repairs & provides substantial savings through protection against inflation & price volatility of consumables during the running of the vehicle.

Our customers can choose from Value Care Gold, Value Care Silver as per the requirement & usage to ensure hassle free, reliable & economic maintenance of the vehicle.

Coverage – Schedule Service and Wear & Tear.

Advantages (Customer Benefits)

- Price protection against rising prices of lubes and parts.
- A higher resale value for your vehicle.
- Peace of mind with Cashless repairs & services.
- Vehicle servicing at a workshop of your choice pan India.
- Covers Repairs including Wear & Tear parts viz. Brakes, Suspension, Wiper, Clutch, Brake Pads, Brake Liners etc.
- Covers Scheduled maintenance services including Lubricants, Parts, Wheel Alignment and Balancing Labour.
- Available at unmatched value.... Huge Savings!!!
- Savings on Goods & Services Tax whenever vehicle attend under AMC.

Available Offers (Types of AMC)

- Silver AMC
- Gold AMC

Silver AMC

Value Care Silver Plan covers the following:

- Scheduled maintenance services at periodic interval of Kms for Labor, Parts & Consumables.



1. Change of Oil Filter, Fuel Filter, Air Filter & Sedimenter.
2. Change of Engine Oil, Transmission Oil.
3. Change of Coolant, Brake Oil & Clutch Fluid*.
4. General Checkup, Wheel Alignment / Balancing (Excluding Balancing Weight).
5. Washing of Vehicle, Wheel greasing as applicable.

Gold AMC

The value care Gold Plan extends your scheduled maintenance cover to include any normal wear and tear items identified during the scheduled service and other vehicle parts that need to replace during the period of cover arising from proper and uniform usage.

Scheduled maintenance services at periodic interval of Kms for Labor, Parts & Consumables.

In addition to coverage mentioned under Silver AMC, the Gold AMC also covers Repairs or Replacement of Wear & Tear Items for both Parts & Labour.

1. Brake Pads, Brake Lines, Wheel Cylinders
2. Clutch Disc, Clutch Cover, Cables, Mountings.
3. Suspension Bush, Wiper Blades, Auxiliary Belt & other Wear & Tear Items
4. Washing of Vehicle, Wheel greasing as applicable.

NOTE

- *AMC is available in the dealership from where you have purchased your vehicle.*
- *We strongly recommend purchase of AMC at time of purchase of your vehicle to get benefit for coverage of Scheduled Services and Wear & Tear parts.*
- *The Dealer Service Marketing Executive shall explain to you the Terms and conditions, Coverage and Owner's responsibility.*
- *One Time payment is to be made to avail AMC offer.*

CAR CARE AND VALUE ADDED SERVICES

- *Please read the offer e-Booklet for further details about coverage and exclusions of various AMCs.*

Owner's Responsibility

- Proper use, maintenance and care of the vehicle in accordance with the instructions contained in the Owner's Manual and Service Booklet. The records of the same to be ensured in Owner's Manual.
- Retention of maintenance service bills.

I / We have been explained the Terms and conditions, Coverage and Owner's responsibility by the Dealer Service Marketing Executive.

I wish to avail / Do not wish to avail Value care AMC policy.

Customer's Signature

Dealer's Signature

VALUE ADDED SERVICES

Why are Corrosion Protection Waxes necessary?

Corrosion is Caused by

Water/salt water, acid rain and atmospheric fallouts.

Critical Areas are

Cavities: joints, crevices, spot welds, underbody

- Corrosion is the most important factor when we talk about the vehicle life. If you treat your car well, you can prolong its life.
- It is very dangerous to drive around in a corroded vehicle.
- Corrosion creeps onto the vehicle internally and externally as well. The most dangerous kind of corrosion is often not discovered until it is too late.

Benefits of Anti - Rust Treatment

- A professionally applied range of world class products offering real value to the new and used vehicle customer.
- The treatment has been developed to withstand the harshest environmental and climatic conditions (rust. Pollutants, stone and gravel impact, etc.)
- Insulates the cabin from external noises..
- Expensive tin work, denting and painting can be avoided.
- Higher resale value for the vehicle.
- Higher safety – uncorroded vehicle
- 10 free checkups available

TATA MOTORS has tied up with **M/s Wurth**, **M/s Autokrom**, **M/s 3M India Lt d** & **M/s Bardahl** for these world class treatment at affordable prices. These treatments are available in all authorized workshops. The Dealer Service Marketing Executive will explain to



CAR CARE AND VALUE ADDED SERVICES

you the benefits and terms and conditions of this treatment.

I / We have been explained the Benefits, Terms and conditions and the prices of these treatments by the Dealer Service Marketing Executive.

I wish to avail / Do not wish to avail extended warrant policy.

Customer's Signature

Dealer's Signature

VEHICLE EXTERIOR ENRICHMENT

Why Vehicles are Painted?

- For Corrosion protection of the metal surfaces.
- Ease of application from other corrosion protection treatments.
- Cheaper than other corrosion protection methods eg. Galvanizing, anodizing.
- For decoration and identification.



Various Environmental Hazards Affecting Paints

Environmental hazards: destroys your vehicle's finish.

Even as your new vehicle rolls off the assembly line, the paint is not protected.

The Enemy

Ultraviolet rays, pollution, tree sap, bird droppings, car wash chemicals, road salt and acid rain.

Benefits

Vehicle Exterior Enrichment

- Removal of medium scratches, orange peel, oxidation, dust nibs etc. & swirl marks from painted surface.
- Restoration of original gloss levels, UV protection after gloss is restored.
- Cleaning & dressing of tyres, Bumpers and all exterior plastic moldings/trims.

TATA MOTORS has tied up with **M/s Autokrom**, **M/s 3M** & **M/s Würth** for this world class treatment at affordable prices.

This treatment is available in all authorized workshops. The Dealer Service Marketing Executive will explain to you the benefits and terms and conditions of this treatment.

CAR CARE AND VALUE ADDED SERVICES

VEHICLE INTERIOR ENRICHMENT

Why Product Your New Car's Fabric Interior

- Someone may soil your vehicle's fabric carpet or seats.
- A significant detractor from your vehicle's resale value.
- A permanent stain on your vehicle's interior fabric.

The Enemy

Drink spills, food stains, mud, ultraviolet rays, traffic and pets

Benefits: Vehicle Interior Enrichment

- Removal of medium stains and dirt from all interior parts of the car i.e., carpet, upholstery and roof lining.
- Cleaning of windshield and all windows (inner and outer surfaces)
- Dressing of all internal plastics (e.g.: door pad trims) and rubber parts.
- The treatment involves cleaning and dressing of all parts of the exposed interiors.
- Specialised protection for seat fabric from liquid spills.

TATA MOTORS has tied up with **M/s Wurth and M/s Autokrom** for this world class treatment at affordable prices. This treatment is available in all authorized workshops. The Dealer Service Marketing Executive will explain to you the benefits and terms and conditions of this treatment.

I / We have been explained the Terms and conditions, Coverage and Owner's responsibility by the Dealer Service Marketing Executive.

I wish to avail / Do not wish to avail Extended warrant policy.

Customer's Signature

Dealer's Signature

WARRANTY - TERMS AND CONDITIONS

WARRANTY - TERMS AND CONDITIONS

We WARRANT each **TATA TIGOR** vehicle and parts thereof manufactured by us to be free from defect in material and workmanship subject to the following terms and conditions:

1. This warranty shall be for a period of **36 months from the date of sale of the car or a mileage of 1,00,000 Kms whichever occurs earlier.**
2. Our obligation under this warranty shall be limited to re-pairing or replacing, free of charge, such parts of the car which, in our opinion, are defective, on the car being brought to us or to our dealers within the period. The parts so repaired or replaced shall also be warranted for quality and workmanship but such warranty shall be co-terminus with this original warranty.
3. Any part which is found to be defective and is replaced by us under the warranty shall be our property.
4. As for such parts as Tyres, Batteries, Audio and / or Video equipment (if any), etc. not manufactured by us but supplied by other parties, this warranty shall not apply, but buyers of the car shall be entitled to, so far as permissible by law, all such rights as we may have against such parties under their warranties in respect of such parts.
5. This warranty shall not apply if the car or any part thereof is repaired or altered otherwise than in accordance with our standard repair procedure or by any person other than from our sales or service establishments, our authorized dealers, service centres or service points in any way so as, in our judgment which shall be final and binding, to affect its reliability, nor shall it apply if, in our opinion which shall be final and binding, the car is subjected to misuse, negligence, improper or inadequate maintenance or accident or loading in excess of such carrying capacity as certified by us, or such services as prescribed in our Owner's Manual are not carried out by the buyer through our sales or service establishments, our authorized dealers, service centres or service points.
6. **This warranty shall not apply to the replacement of normal wear parts, including without limitation, spark plugs, drive belts, hoses, wiper blades, fuses, clutch disc, brake shoes, brake pads, cables and all rubber parts (except oil seal and glass run).**
7. This warranty shall not cover any inherent normal deterioration of the car or any of its parts arising from the actual use of the car or any damage due to negligent or improper operation or storage of the car.
8. This warranty shall not apply to normal maintenance services like oils & fluid changes, head lamps focusing, fastener retightening, wheel balancing and alignment, tyre rotation, adjustment of valve clearance, fuel timing, ignition timing and consumables like bulbs, fuel, air & oil filters and gas leaks in case of air conditioned cars.
9. This warranty shall not apply to any damage or deterioration caused by en-

WARRANTY - TERMS AND CONDITIONS

vironmental pollution or bird droppings. Slight irregularities not recognized as affecting the function or quality of the vehicle or parts, such as slight noise or vibration, defects appearing only under particular or irregular operations are items considered characteristics of the vehicle.

10. This warranty shall be null and void if the car is subjected to abnormal use such as rallying, racing or participation in any other competitive sport. This warranty shall not apply to any repair or replacements as a result of accident or collision.
11. This warranty is expressly in lieu of all warranties, whether by law or otherwise, expressed or implied, and all other obligations or liabilities on our part and we neither assume, nor authorize any person to assume on our behalf, any other liability arising from the sale of the car or any agreement in relation thereto.
12. The buyer shall have no other rights except those set out above and have,

in particular, no right to repudiate the sale, or any agreement or to claim any reduction in the purchase price of the car, or to demand any damages or compensation for losses, incidental or indirect, or inconvenience or consequential damages, loss of car, or loss of time, or otherwise, incurred or accrued.

13. Any claim arising from this warranty shall be recognized only if it is notified in writing to us or to our authorized dealer without any delay soon after such defects as covered & ascertained under this warranty.

14. This warranty is fully transferable to subsequent vehicle owner. Only unexpired remaining period of warranty applies.

15. We reserve our rights to make any change or modification in design of the car or its parts or to introduce any improvement therein or to incorporate in the car any additional part or accessory at any time without incurring any obligation to incorporate the same in

the cars previously sold.

EXTENDED WARRANTY - TERMS AND CONDITIONS

TATA MOTORS recommends the purchase of its extended warranty program.

Coverage - Mechanical + Electrical

Benefits

- Insures you against unforeseen break down repair bills.
- Documentation is simple and hassle free.
- Near cashless & speedy claim

Term

Extended Warranty Operating Period for each eligible motor car shall commence on the expiry of the Tata Motors' Vehicle warranty period and shall remain valid till the expiry of policy.

Extended Warranty is available in the dealership from where you have purchased your vehicle. We strongly recommend purchase of Extended Warranty at time of purchase of your vehicle. Extended Warranty can be availed till warranty period from date of purchase of vehicle. The Dealer Service Marketing Executive shall explain to you the Terms and conditions, Coverage and Owner's responsibility.

- The extended warranty comes into force once the manufacturer's warranty expires.
- It is more restrictive as by the time it comes into force the vehicle is already 36 months old.

What is Covered?

Mechanical / Electrical break down as defined in this warranty and confirmed by the dealer within the stipulated terms and conditions.

TATA MOTORS dealer shall either repair or replace any part found to be defective with a new part or an equivalent at no cost to the owner for parts or labour.

Such defective parts which have been replaced will become property of TATA MOTORS PASSENGER VEHICLES LIMITED.



WARRANTY - TERMS AND CONDITIONS

What is not Covered?

Please refer the Extended Warranty Booklet for details of the exclusion list. Soft copy of which will be provided by dealer.

Owner's Responsibility

- Proper use, maintenance and care of the vehicle in accordance with the instructions contained in the Owner's Manual and Service Booklet. The records of the same to be ensured in Owner's Manual.
- Retention of maintenance service bills.

I / We have been explained the Terms and conditions, Coverage and Owner's responsibility by the Dealer Service Marketing Executive.

I wish to avail / Do not wish to avail extended warrant policy.

Customer's Signature

Dealer's Signature

ENVIRONMENT SAFETY

TATA MOTORS PASSENGER VEHICLE LIMITED. is committed to produce vehicles using environmentally sustainable technology. A number of features have been incorporated in TATA MOTORS passenger vehicles which have been designed to ensure environmental compatibility throughout the life cycle of the vehicle. We would like to inform you that your vehicle meets emission norms and this is being regularly validated at the manufacturing stages.

As a user you too can protect the environment by operating your vehicle in a proactive manner. A lot depends on your driving style and the way you maintain your vehicle. We have given a few tips for your guidance.

Driving

- Avoid frequent and violent acceleration.
- Do not carry any unnecessary weight in the vehicle as it overloads the engine. Avoid using devices requiring high power consumption during slow

city traffic condition.

- Monitor the vehicle's fuel consumption regularly and if showing rising trend get the car immediately attended at the Company's Authorised Service Outlets.
- Switch off the engine during long stops at traffic jams or signals. If you need to keep the engine running, avoid unnecessary revving it or stopping and starting.
- It is not necessary to rev the engine before turning it off as it unnecessarily burns fuel.
- Shift to higher gears as soon as it is possible. Use each gear upto 2/3rd of its maximum engine speed.
- A chart indicating gear shifting speeds is given in this book.

Maintenance

- Ensure that recommended maintenance is carried out on the vehicle regularly at the Authorised Service Outlets.
- As soon as you see any leakages of oil

or fuel in the vehicle we recommend to get it attended immediately.

- Use only recommended grades and specified quantity of lubricants.
- Get your vehicle checked for emission periodically by an authorised dealer.
- Ensure that fuel filter, oil filter and breather are checked periodically and replaced, if required, as recommended by TATA MOTORS.
- Do not pour used oils or coolants into the sewage drains, garden soil or open streams. Dispose the used filters and batteries in compliance with the current legislation.
- Do not allow unauthorized person to tamper with engine settings or to carry modifications on the vehicle.
- Never allow the vehicle to run out of fuel.
- Parts like brake liners, clutch discs should be vacuum cleaned. Do not use compressed air for cleaning these parts which may spread dust in the atmosphere.

ENVIRONMENT SAFETY

While carrying out servicing or repairs of your vehicle, you should pay keen attention to some of the important engine aggregates and wiring harnesses which greatly affect emission. These components are:

1. Engine Management System (EMS)
 - ECU
 - EMS sensors & Corresponding wiring harness
 - Electrical connections to all sensors & actuators
2. Fuel Injection System
 - Fuel Pump
 - Fuel filter
 - Fuel Injectors
3. Air intake System
 - Air filter & connecting pipes
4. Exhaust after Treatment System
 - Catalytic Converter
5. Ignition System
 - Ignition coil
 - Spark plug

This Owner's manual contains further information on driving precautions and maintenance care leading to environment protection. Please familiarize yourself with these aspects before driving.

Customer's copy



PDI Coupon

»X»PRES-T

Pre Delivery Inspection

Dealer's copy



PDI Coupon »X»PRES-T

Pre Delivery Inspection

AVAIL ALL SERVICES TO GET BENEFIT OF WARRANTY

Owner's Name:

VIN No.:

Engine / Motor No.:

Reg. No.:

ODO Reading:

Date of Service:

This Coupon entitles for free labour jobs.(Refer maintenance section)

Owner's Name:

VIN No.:

Engine / Motor No.:

Reg. No.:

Date of Sale:

Service Dealer code:

ODO Reading:

Date of Service:

I hereby certify that the PDI has been carried out to my entire satisfaction.

Service Dealer's Stamp & Signature

Customer's Signature

Service Dealer's Stamp & Signature

(Free Service coupons are valid at all TATA Authorized Service Centers in India)



Customer's copy

1st Free Service Coupon

X|PRES-T

Valid for 1000 - 2000 kms. OR 2 months,
Whichever is earlier

Owner's Name:

VIN No.:

Engine / Motor No.:

Reg. No.:

ODO Reading:

Date of Service:

Service Dealer's Stamp & Signature



Dealer's copy

TATA 1st Free Service Coupon X|PRES-T

Valid for 1000 - 2000 kms. OR 2 months, whichever is earlier.

AVAIL ALL SERVICES TO GET BENEFIT OF WARRANTY

This Coupon entitles for free labour jobs.(Refer maintenance section)

Owner's Name:

VIN No.:

Engine / Motor No.:

Reg. No.:

Date of Sale:

Service Dealer code:

ODO Reading:

Date of Service:

I hereby certify that the service has been carried out to my entire satisfaction.

Customer's Signature

Service Dealer's Stamp & Signature

(Free Service coupons are valid at all TATA Authorized Service Centers in India)



Customer's copy

2nd Free Service Coupon

»X»PRES-T

Valid for 00 - 00 kms. OR 6 months,
whichever is earlier

Owner's Name:

VIN No.:

Engine / Motor No.:

Reg. No.:

ODO Reading:

Date of Service:

Service Dealer's Stamp & Signature



Dealer's copy

TATA 2nd Free Service Coupon

»X»PRES-T

Valid for 00 - 00 kms. OR 6 months, whichever is earlier.

AVAIL ALL SERVICES TO GET BENEFIT OF WARRANTY

This Coupon entitles for free labour jobs.(Refer maintenance section)

Owner's Name:

VIN No.:

Engine / Motor No.:

Reg. No.:

ODO Reading:

Date of Sale:

Date of Service:

Service Dealer code:

I hereby certify that the service has been carried out to my entire satisfaction.

Customer's Signature

Service Dealer's Stamp & Signature

(Free Service coupons are valid at all TATA Authorized Service Centers in India)

Customer's copy



3rd Free Service Coupon

»XPRES-T

Valid for ,500 – 1 ,500 kms. OR 12 months, whichever is earlier

Owner's Name:

VIN No.:

Engine / Motor No.:

Reg. No.:

ODO Reading:

Date of Service:

Service Dealer's Stamp & Signature

Dealer's copy



TATA 3rd Free Service Coupon »XPRES-T

Valid for ,500 – 1 ,500 kms. OR 12 months, whichever is earlier.

AVAIL ALL SERVICES TO GET BENEFIT OF WARRANTY

This Coupon entitles for free labour jobs.(Refer maintenance section)

Owner's Name:

VIN No.:

Engine / Motor No.:

Reg. No.:

ODO Reading:

Date of Sale:

Date of Service:

Service Dealer code:

I hereby certify that the service has been carried out to my entire satisfaction.

Customer's Signature

Service Dealer's Stamp & Signature

(Free Service coupons are valid at all TATA Authorized Service Centers in India)



TATA MOTORS | SERVICE

RESPONSIVE • RELIABLE • BEST VALUE

TATA MOTORS | SERVICE
RESPONSIVE

24x7
ROADSIDE ASSISTANCE
1800 209 8882

TATA MOTORS | SERVICE
RELIABLE

DOORSTEP SERVICE
MOBILE SERVICE

TATA MOTORS | SERVICE
RESPONSIVE

ONLINE SERVICE
APPOINTMENT
AT A CLICK

TATA MOTORS | SERVICE
RESPONSIVE

QUICK REPAIR
REPAIR IN MINUTES

TATA MOTORS | SERVICE
RELIABLE

SPEED-O-SERVICE
FASTER SERVICE
DELIVERY

TATA MOTORS | SERVICE
RELIABLE

REFINISHING SOLUTIONS
BODY & PAINT

TATA MOTORS | SERVICE
RELIABLE

DIAGNOSTIC EXPERT
HIGH SKILLED TECHNICIAN

TATA MOTORS | SERVICE
RELIABLE

QUALITY SERVICE
SERVICE QUALITY
ASSURANCE

TATA MOTORS | SERVICE
RELIABLE

**ASSESSMENT TRAINING
AND CERTIFICATION**
BUILDING COMPETENCY

TATA MOTORS | SERVICE
BEST VALUE

EXTENDED WARRANTY
UP TO 6 YEARS

TATA MOTORS | SERVICE
BEST VALUE

RAPID REPAIR
MINOR BODY REPAIRS

TATA MOTORS | SERVICE
BEST VALUE

VALUE CARE
MAINTENANCE PLANS

